

# ***dynaco*** **STEREO 120**

SERIAL NUMBER

This number must be mentioned in all communications concerning this equipment.

## **INSTRUCTIONS FOR ASSEMBLY OPERATION**

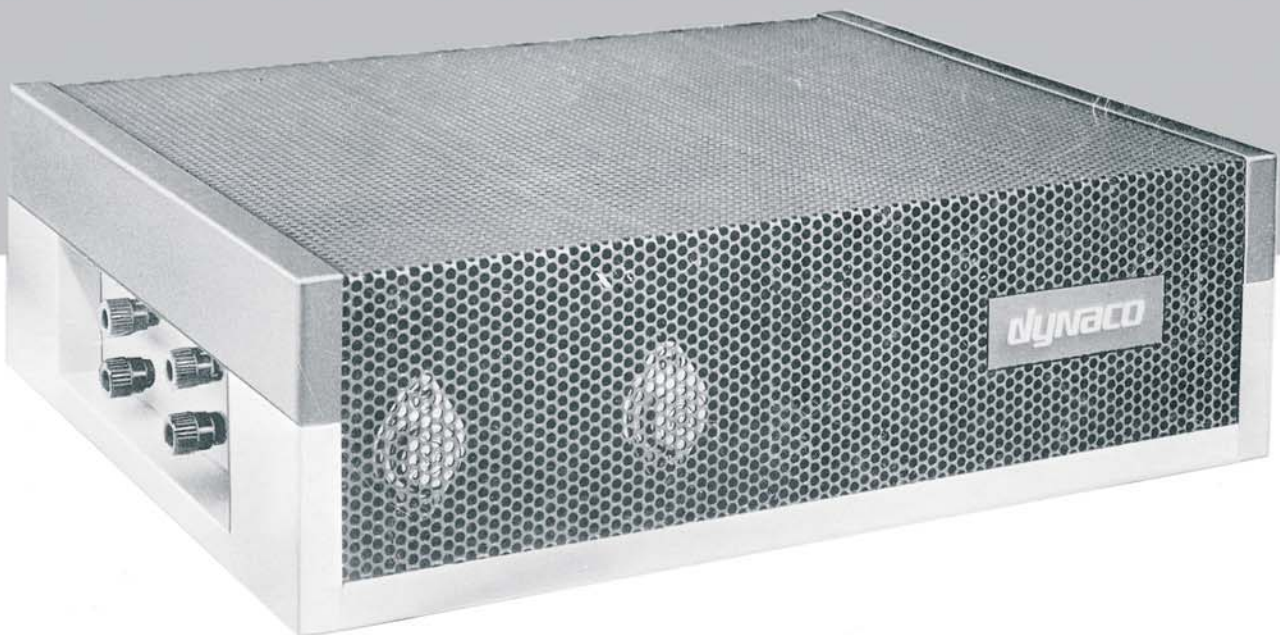

**Price \$1.00**

patents pending

929117

***dynaco inc.*** 3912 Powelton Ave. Philadelphia, Pa. 19104 U.S.A.

## CONTENTS

Operating Instructions .....	3	Assembly Instructions .....	
Technical Information .....	5	Schematic Diagram .....	10
Circuit Description .....	5	In Case of Difficulty .....	17
Performance Testing .....	5	Service Information for the Technician .....	18
Dynaco Preamplifiers .....	6	Pictorial Diagram .....	Back Cover Foldout
Center Channel .....	6	Factory Service and Warranty .....	Back Cover
240 Volt Connections .....	7	Parts List .....	Back Cover

## SPECIFICATIONS

**FREQUENCY RESPONSE:** 5 Hz to 100 kHz  $\pm 0.5$  db.

**POWER BANDWIDTH (IHF):** 5 Hz to 50 kHz half power output at less than 0.5% total harmonic distortion into an 8 ohm load.

**HARMONIC DISTORTION:** *Less than 0.5%* at any power level up to 60 watts per channel into 8 ohms at any frequency between 20 Hz and 20 kHz. Distortion reduces at lower power levels.

**INTERMODULATION DISTORTION:** *Less than 0.5%* at any power level up to 60 watts per channel into 8 ohms with any combination of test frequencies. Distortion reduces at lower power levels.

**NOISE:** 95 db below rated output *unweighted* with shorted input; 100 db down by IHF standards.

**DAMPING FACTOR:** Greater than 40 from 20 Hz to 20 kHz.

**SEPARATION:** More than 70 db from 20 Hz to 20 kHz.

**INPUT:** 100,000 ohms; 1.5 volts for 60 watts output.

**SEMICONDUCTOR COMPLEMENT:** 15 transistors; 15 diodes.

**SIZE:** 13" x 10 $\frac{1}{2}$ " x 4". **WEIGHT:** 20 lbs.

**MAXIMUM POWER CONSUMPTION:** 400 watts.

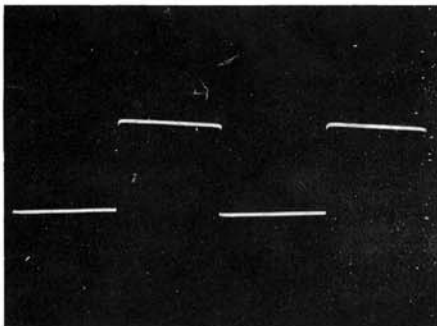

100 Hz

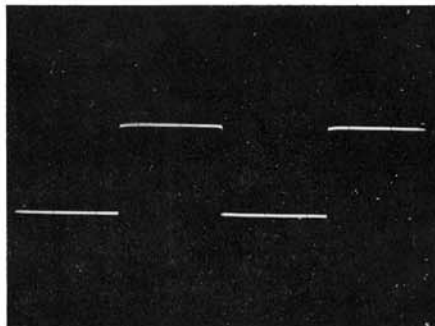

1 kHz

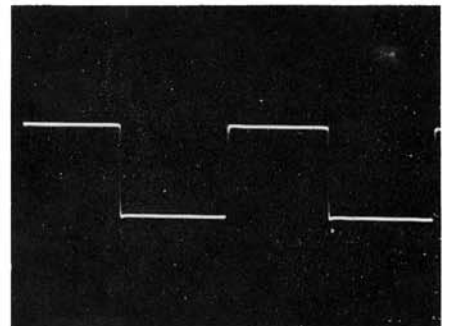

10 kHz

**SQUARE WAVE PERFORMANCE:** This is a good indication of linearity from 10 Hz to 100 kHz, since good square wave reproduction requires bandwidth in excess of 1/10th to 10 times displayed frequency.

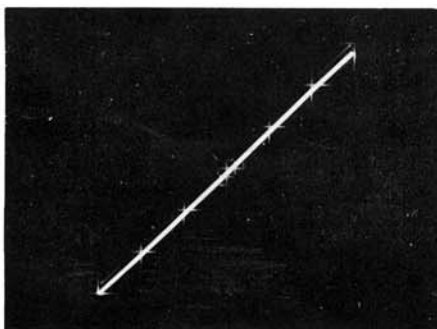

2 kHz

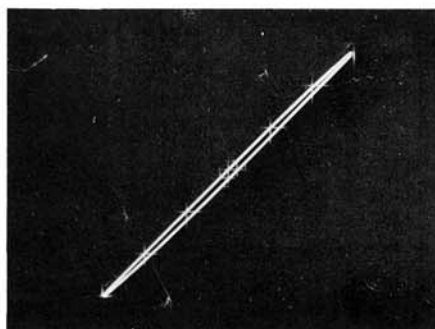

20 kHz

**INPUT-OUTPUT LINEARITY AT 60 WATTS**

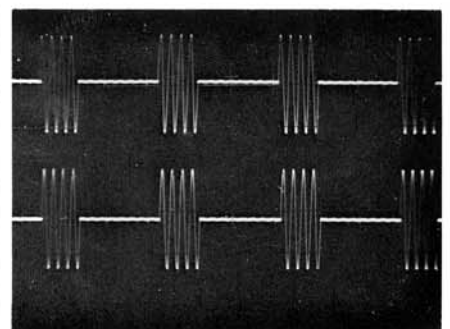

**tone BURST:**

4 cycle 20 kHz through amplifier at 60 watts is indistinguishable from generator (below).

# THE DYNACO STEREO 120

Do not attempt to install or use this amplifier until the section "Operating Instructions" has been carefully read.

## INTRODUCTION

The Dynaco Stereo 120 is an all silicon transistor basic power amplifier for use with separate preamplifiers such as the Dynaco PAS-3X or PAT-4, or for use with tape recorders or tuners such as the Dynaco FM-3 which have their own volume controls. The Stereo 120 contains two 60 watt amplifiers on one chassis with a common power supply.

Although the Stereo 120 is a solid state device, containing transistors and similar semi-conductors, it has been designed to be used under normal conditions without special safety precautions, just as if it were a high grade tube amplifier. Thus it can be connected to source and speaker components and used with confidence in all conventional arrangements. There are no circuit breakers, speaker fuses, or other resettable devices to impede the use of the Stereo 120 under any reasonable conditions of use or abuse. This is achieved by using novel circuits (on which patents are pending) which automatically and instantly protect the amplifier.

The components in the Stereo 120 are of the highest quality to protect against failure, both now and for many years in the future. All parts are used conservatively with

close tolerances to assure proper operation, and etched circuit modules are pretested under actual use conditions to ensure that every unit, after assembly, will meet the specifications normally associated with laboratory prototypes.

The specifications of the Stereo 120 speak for themselves. The distortion at low levels is comparable to that of the finest tube designs, while the high power distortion remains inaudible. Specifications do not reveal all the facets of sound quality, however. In use with varying program material, the Stereo 120 justifies its design efforts to have qualities of ease and naturalness always sought and rarely achieved in solid state designs. There is no extra brightness or stridency which is unfortunately sometimes attributed to high fidelity sound, but rather there is an impression of limitless range and effortless handling of the highest power peaks.

Like any precision equipment, the superior capabilities of the Stereo 120 will best be obtained when it is utilized properly. Therefore, read these instructions, and make the specified connections to the input audio source and to the loudspeakers *before connecting the amplifier to a source of AC power.*

## OPERATING INSTRUCTIONS

### Connection from preamplifier or other signal source

Since the Stereo 120 is a *basic* stereo power amplifier, it has no operating controls; it should be supplied with an audio signal from a stereo preamplifier or similar signal source (such as a multiplex tuner or a stereo tape player with a volume control). Most preamplifiers can supply the required 1.5 volt signal and can operate into the 100,000 ohm input impedance of the Stereo 120. In particular, the Dynaco PAS-3X (or PAS-2X) is recommended with the Stereo 120, as well as the solid state PAT-4 preamplifier. With earlier Dynaco preamplifiers such as the PAS-2, PAS-3 or a pair of PAM-1s, a simple change of a resistor on each channel will provide the proper match for the Stereo 120. The installation of this resistor in the preamplifier is described in a later section of this manual. Earlier Dynaco preamps which have been modified by adding the TC-3X tone control kit are directly useable.

If the Stereo 120 is being used with another make of preamplifier, tuner or tape recorder, you should check with the manufacturer of the equipment to see if it is suitable for 100,000 ohm load impedance.

From the preamplifier, or other source, conventional single-conductor shielded cables with standard "phono" plugs should be connected to the inputs of the Stereo 120. Make certain that the plugs are pushed fully into the sockets, and that the outer ground connections on the plugs are gripping the sockets tightly at each end. The maximum length of these shielded cables is determined by the output impedance of the preamplifier and can generally be as much as 25 feet if the Stereo 120 is to be remotely installed.

### Connection to loudspeakers

The Stereo 120 is supplied with two pairs of different color binding posts, one pair for each channel output. The "common" terminal is black, and the "hot" connection is red. The two black posts are electrically connected internally, and are also connected to the chassis, so that the amplifier may be used with special output connections which require common grounds if desired. *You must be certain that the polarity of such output connections is never reversed, and that the "hot" sides are never accidentally connected together in accessory equipment.*

The binding posts accept single "banana plugs", double "banana plugs" (such as the General Radio type 274-MB), spade lugs, or simply stranded wire. If stranded wire is used (as from lamp cord) the wire ends preferably should be "tinned" with solder first to avoid fraying. To connect the wire, unscrew the cap until the horizontal hole in the metal shaft is uncovered, push the wire end through the hole and tighten the cap. Make certain that no wire strands are touching another post or the chassis. The banana plugs are inserted into the ends of the posts. These plugs are available from any radio parts distributor.

Quality loudspeakers whose rated impedances are between 4 and 16 ohms can be connected directly to the binding posts. For short distances (25 feet or less) ordinary #18 lamp cord can be used. For longer distances, it is suggested that heavier cable (#16 or #14) be used.

The terminals on loudspeakers are marked in different ways, and sometimes are left unidentified. They may be (+) and (-), (1) and (2), or (C) and (8 ohms) for

example. These markings are provided so that proper phasing of a pair of speakers can be maintained. It is not necessary when connecting the leads from the amplifier to the speaker to be sure that the red amplifier terminal is connected to the (+) speaker terminal, or that the (C) terminal is connected to the black amplifier post. However, once the "sense" of the wiring has been established by connecting one speaker to the amplifier, the second speaker will be in phase. With ordinary lamp cord, this is easy, because one lead is coded — usually either with a "tracer" thread wound around one of the wires, or with a slight molded ridge on the outer plastic insulation of one conductor, or with different color conductors.

The nominal power rating of the Stereo 120 is based on a load impedance of 8 ohms. Loudspeakers with impedances of 4 and 16 ohms can also be utilized with slight reduction of the maximum power capability at some frequencies. Since all loudspeakers have varying impedance characteristics with frequency, an optimum match to any amplifier is a compromise over much of its range. The maximum power output into a given speaker varies with frequency with both tube and transistor amplifiers, because the speaker's rated impedance is typically its minimum impedance. The Stereo 120 can deliver not less than 50 watts into the 4 ohm AR-3, for example, throughout the speaker's useable range. With a 16 ohm speaker, maximum power can be expected to be about 40 watts at most frequencies. This question has been largely overlooked in the past because the output transformers in tube amplifiers could match to different nominal speaker impedances, but the problem was not significantly different. A more detailed explanation of amplifier power output characteristics is available on request from Dynaco.

### Monophonic operation

The outputs of the Stereo 120 (and other transistor power amplifiers) should *not* be connected together (paralleled) in an attempt to obtain higher power output. If they are paralleled, there is little benefit of power increase under practical conditions, and there is a possibility of damage to the amplifier. Using isolating resistors between the two channels wastes power and destroys the amplifier's damping factor.

For higher power monophonic applications, the preferred procedure is to drive each channel of the Stereo 120 with identical signals (using the "A+B" or "Mono" position on the preamplifier, or a "Y" connection) and connect each output channel to a *separate* loudspeaker system. This has the advantage that the speaker will be operated with less likelihood of overload, for speakers are rarely designed to handle more than 60 watts of sustained power.

Of course, either channel may be used independently as a 60 watt mono amplifier by simply leaving the input and output of the second channel unconnected. No "load" is required on the unused channel when there is no input signal.

### Cautions to be observed

The Stereo 120 contains circuits which will provide nearly complete protection against abuse (including the cautions noted below), but you should not challenge fate. We all know that parachutes are quite safe — but why jump to test one? The need for protective circuitry in solid state equipment is a direct result of its inherent susceptibil-

ity to failure compared with the ruggedness of vacuum tube equipment. You will avoid possible damage to costly transistors and other components if you follow these few simple rules:

1. Do not connect or disconnect inputs or outputs when the amplifier power is on.
2. If you hear any abnormal noises, turn off the equipment and locate and eliminate the source of the noises before using the Stereo 120. These noises may result from partially connected audio cables or similar faults not connected with the Stereo 120, but they can be signals or symptoms of signals of excessive amplitude.
3. The volume control of the preamp or other source should be at a low setting when the amplifier is turned on. At any time that the sound is weak or garbled, locate the trouble *before advancing the volume control*.
4. Do not operate a tape recorder in the fast wind or rewind mode when the volume control is advanced, as this could produce large signals at inaudible frequencies.
5. Avoid any output connection system which risks connecting the "hot" side of one channel to the "hot" side (red terminal) of the other channel. This is not likely in any properly wired system or accessory, but an accidental change of polarity in the connections to a system requiring common ground connections could be costly. Of particular note: headphone junction boxes.
6. If it is necessary to switch from one speaker to another when the amplifier is turned on (as in a distribution system to several rooms) *always make the changes at a low setting of the preamp volume control*. The setting of individual speaker level controls is unimportant.
7. Avoid shorting together the two wires to a loudspeaker, and do not use any switches in the output which are of the shorting type. Be sure that no strands of connecting wires are free to touch anything except the intended terminal.

### Amplifier operation

Now you are ready to plug the line cord into the proper AC outlet and listen to the system. A switched outlet on the preamplifier will be the most convenient arrangement, for then the power switch on the Stereo 120 can be left on and switching will be automatic when the preamplifier is turned on. If the Stereo 120 is inadvertently left on for a lengthy period of time, no problems will be encountered. The components do not get hot with extended use under normal or under no-signal conditions. The slight warmth felt when the unit is on is from some power resistors on the amplifier boards. The transistors and other components will remain cool except under high signal conditions. With sustained high power output it is normal for the bottom to become much warmer than the cover, because the heat sinks dissipate heat through the chassis.

Since there is little heat in normal use, the Stereo 120 does not require the degree of ventilation needed for a tube amplifier, though what heat is generated must be effectively dissipated. The amplifier may be placed almost anywhere, in any position, as long as it is not blanketed with magazines, records or similar obstructions. If the amplifier is used where sustained high power output is required (and transistors heat up the fastest at about half the maximum power output) adequate ventilation is necessary. At full power continuous output on both channels, the Stereo 120 draws almost 400 watts and it, like any other transistor amplifier, will generate as much heat as a comparable tube amplifier.

Those who desire to use headphones with this amplifier will find that most headphone manufacturers make adapters available which provide the necessary level controls or resistors to reduce the power to the headphones, and to maintain low noise. General information on this subject is available on request from Dynaco.

### Checking speaker phasing

The simplest procedure for determining correct speaker phasing is to play a monophonic program (turn the pre-amplifier to "A+B" or "Mono") through both speakers.

Then if the phasing is correct, there will be a smooth transition of sound as you move from one speaker to the other. If the speakers are not in phase, there will be an abrupt shift from one to the other at some point between the two. If convenient, an alternative method is to face the two speakers toward each other about 6 inches apart, and when the "Common" and "Hot" leads to one speaker are interchanged, there will be a noticeable loss of bass energy when the speakers are out of phase. Only the pair of leads from the amplifier to *one* of the speakers should be interchanged to correct the phasing, and there is no need to alter the phasing once the speakers are properly connected.

## TECHNICAL INFORMATION

### CIRCUIT DESCRIPTION

The Stereo 120 has a number of unique circuit features on which there are several patent applications. They contribute to the amplifier's exceptionally low distortion, long term reliability, resistance to abuse, and to its remarkable degree of reproducibility which marks a truly successful design. Those not interested in the technology may omit this section. A more detailed technical description for servicing will be found in a later section of this manual.

The power supply utilizes a full wave silicon diode bridge rectifier. It is regulated against changes in line voltage, and its output is stabilized so that changes in the load caused by varying signals will not result in voltage shifts. This regulation affords five advantages over conventional amplifiers: 1) It assures that the Stereo 120 will meet its performance specifications over a wide range of line voltages. 2) It protects the amplifier from damaging AC-line transients. 3) It maintains the prescribed operating margins to assure long transistor life. 4) It provides a "clean" overload characteristic. 5) It avoids transient distortion caused by changing operating parameters when the supply voltages change under heavy current demands — a normal characteristic of Class B amplifier circuits.

Transistors Q7, Q8 and Q9, and a Zener diode provide voltage regulation to within 1%. Conventional regulators are capable of self-destruction with sustained, excessive loading of the supply. In the Stereo 120 a novel circuit configuration switches the supply from a fully regulated, low impedance source to a de-regulated, high impedance one when a predetermined maximum current is reached. Thus the supply effectively regulates up to a certain point, and then protects both itself and the load from damage that could result from excessive current.

The power supply protection prevents it from delivering normal voltages if the input signal is excessive at the instant of turn-on. Once the input level is reduced, the supply will come on, and operation is no longer affected. An electronic delay at turn-on avoids the sharp "thump" in the signal commonly associated with some solid state amplifiers.

The audio portion of the Stereo 120 also includes unique circuitry to provide an unusual amount of protection while delivering exceptional performance. Transistors Q1 and Q2 are a direct-coupled feedback pair providing a high degree of stability and great linearity. This pair drives the power section, transistors Q3 through Q6, which are direct-coupled and include DC feedback stabilization. These four transis-

tors act as a push-pull power transformer in that they do not have voltage gain, but they transform the signal from high impedance to low impedance. All six transistors in the driver and power sections are included in one overall feedback loop.

Like the power supply protection, the amplifiers are also designed to *reduce* — not just limit — the current through the output stage when there is any tendency to exceed a reference limit as a result of excessive drive signals or heavy loads. This protects both the load (the loudspeaker) and the source (the output transistors).

In the Stereo 120 the output transistors are operated *without quiescent current* and without the consequent heat rise caused by the bias current, eliminating the need for temperature compensating devices. However, the Stereo 120 does not exhibit any signs of the "Class B notch" commonly attributed to a lack of bias current.

The output signal is taken from the junction of Q5 and Q6 through coupling capacitor C7, which prevents DC from reaching the speaker. An output capacitor large enough to assure unrestricted low frequency response was chosen instead of the conventional and less costly plus-minus output circuit. It eliminates any need for balance adjustments or matching of components, and assures speaker protection in the event of output transistor failure.

All of the large capacitors used in the Stereo 120 are special high-purity "computer grade" electrolytics chosen for maximum reliability. The output capacitors also serve as convenient forms for small value air-core chokes in the output which, in conjunction with an R-C circuit, roll off the response in the RF region (above 500,000 Hz), reducing interference and affording absolute stability under all circuit conditions.

### PERFORMANCE TESTS

Special care must be taken when subjecting transistorized amplifiers to laboratory tests. Solid state circuits draw much more current at the frequency extremes than in the mid-band, and tests with other than the 8 ohm load for which the amplifier is designed may also draw higher current. High current raises transistor temperatures, causing increased current demand, so tests must be performed quickly under these conditions to avoid the action of the protective cut-back circuits which limit the current in the Stereo 120 for safety reasons. The action of the protective circuitry may yield erroneous results, such as a notably lower apparent power output for rated distortion.

High power measurements should first be "set up" with a low input signal, and then raised to a previously determined level for a quick reading. The extended power and frequency response of the Stereo 120 requires that even low power tests above and below the audible range be made quickly to avoid protective cut-back. This limits the practical duration of high frequency square wave tests, for example.

Prolonged tests at high power levels, at the frequency extremes, or with abnormal load impedances require adequate thermal recovery time. Without it, the transistors are rendered more susceptible to subsequent overload, and the safety margin afforded by the protective circuits is sharply reduced. Callous disregard of these effects may result in eventual failure, for there is no such thing as absolute protection against deliberate abuse.

The heat which is generated is dissipated through the heat sinks to the chassis, so the bottom of the amplifier will get quite hot during tests. Remember that the maximum dissipation in transistorized circuits occurs at about half power. At maximum current drain, the Stereo 120 will dissipate as much heat as two 60 watt tube amplifiers, so adequate ventilation must be provided.

The Stereo 120 includes a protection circuit which keeps the power supply shut down if a high prolonged signal is applied to the input before the amplifier is switched on. Prolonged operation in this mode will cause R24 in the power supply to overheat. Reducing the input gain will allow the amplifier to turn on normally, with no subsequent effect on the program material.

The line fuse in the Stereo 120 has been chosen to provide maximum protection while allowing short duration currents in excess of its rating. The current demand for both channels operating at full power steady-state at 20 KHz (the severest test), for example, will slightly exceed the fuse rating, but the slo-blo fuse will handle this for several seconds.

When making full power tests at the frequency extremes, it is important that the line voltage be corrected for power line drop because of the high current demand. The reserve regulation capacity of the supply will be limited by excessive line losses, and the indicated distortion may rise at maximum power when both sides are driven simultaneously.

### USE WITH DYNACO PREAMPLIFIERS

The Dynaco PAS-2X, PAS-3X and PAT-4 preamplifiers and the Dynatuner may be used directly with the Stereo 120 without modification. Older model Dynaco PAS-2 and PAS-3 preamplifiers may be updated to the latest "X" series by adding the TC-3X tone control modification kit. Buy the TC-3X from your dealer or order it directly from Dynaco for \$10.00 (no C.O.D.'s, please). You may also modify the Dynaco PAM-1, PAS-2 and PAS-3 preamps to accommodate the 100,000 ohm input impedance of the Stereo 120 without making the tone control changes of the TC-3X. This is accomplished as follows in the PAS-2 and PAS-3 stereo preamplifiers:

1. Purchase two 100,000 ohm, 1/2 watt, 10% tolerance resistors.
2. Unsolder and discard the two 510,000 ohm (green-brown-yellow) resistors connected to the audio output sockets on the back panel of the preamplifier and re-

place them with the 100,000 ohm resistors. Solder all connections.

3. Snip out and discard the two 62,000 ohm (blue-red-orange) resistors on the PC-5 circuit board adjacent to eyelets #8 and #18. This completes the modification.

The modification for the PAM-1 mono preamp is as follows:

1. Purchase one 100,000 ohm, 1/2 watt, 10% tolerance resistor for each preamplifier.
2. Unsolder and discard the 510,000 ohm (green-brown-yellow) and the 62,000 ohm (blue-red-orange) resistors between lugs #2 and #3 of the 7-lug terminal strip in the preamp. Solder the 100,000 ohm resistor between these two lugs. This completes the change.

### DYNACO CENTER CHANNEL SYSTEM FOR 3 SPEAKER STEREO

This method of deriving the center (third) channel of a stereo system is an exclusive Dynaco development which utilizes special circuitry in the Dynaco PAS-2X, PAS-3X and PAT-4 preamplifiers to provide the proper in-phase (A+B) signal without loss of stereo separation and without the need for an additional amplifier. It is useful where the left and right speakers must be widely separated, and it also enables the use of the third channel speaker as a monophonic system in another location.

It should be recognized, however, that a two channel system will have a wider apparent sound source than any system utilizing a center speaker in a derived third channel arrangement, if the spacing between the left and right channel speakers remains the same. In order to maintain equivalent spread of sound, somewhat greater spacing between the outside speakers is required in any 3 speaker system.

The connection of the 3 speakers is diagrammed below. The use of 3 *identical* speakers is essential to achieve the most natural sound throughout their range. In any event, all speakers must have the same efficiency, and the left and right speakers should be identical. Connection of dissimilar speakers will reduce separation and adversely affect spatial orientation. The use of individual level controls in series with any of the speakers will also reduce separation. They are neither necessary nor desirable when matched speakers are used. If the speaker systems provide controls for the adjustment of relative tweeter or midrange levels, these should be set before the system is adjusted as described below. Be sure all speakers are correctly phased.

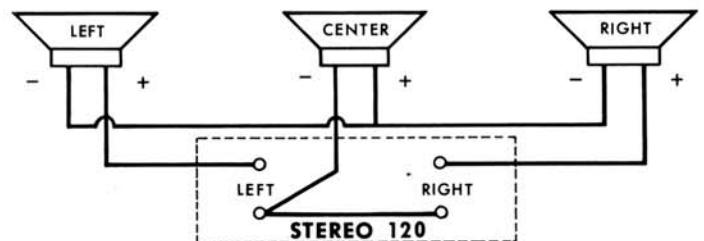

Adjusting the system is easy. Set the tone controls in their "flat" centered positions, switch off the loudness compensation and scratch filter, and adjust the volume control for normal listening level. The Blend (Stereo-Mono) Switch on the PAS-2X or PAS-3X preamplifier should be turned to the smallest rectangle. Now use a monophonic source so that identical signals will be fed to both channels, and temporarily remove one of the wires to the center speaker. Either wire gives the same result. Adjust the balance control for *minimum* sound output. If necessary, the

balance control knob can be slipped off the shaft and recentered so that the upright pointer indicates the position of precise balance. Then reconnect the speaker wire.

Now all program material, both stereo and mono, can be played without changing the blend control from the position indicated by the smallest rectangle, and generally without any need to readjust the balance control. Monophonic programs will appear predominantly in the center speaker. Stereo programs will retain their separation, and when the listener changes position, the apparent distribution of sound will not shift, so that the stereo perspective will be less dependent on the listening position. If you wish to turn off the center channel speaker, normal two channel stereo is obtained by shorting across the terminals of the center speaker.

If the third channel is to be used as a remote monophonic speaker, it is advisable to first install it as a center channel of the stereo system for proper balance adjustment as indicated above. It then may be moved to another area.

Additional information regarding the use of a third amplifier for 3 channel systems is available on request from Dynaco.

## CONNECTIONS FOR 240 VOLT AC LINE

The FA-704 power transformer supplied in the Stereo 120 may be connected for a 240 volt AC line as well as for the standard 120 volt AC line, which is how the transformer is connected unless this manual is stamped "240 volt". The transformer has dual primary windings, and they are connected in parallel for 120 volts, and in series for 240 volts. Steps 26 and 29 on page 12 and the diagrams on pages 19 and 20 of this manual detail both arrangements.

The 3 ampere slo-blo fuse supplied with 120 volt wiring should be replaced with a 1.5 ampere slo-blo fuse when the amplifier is wired for 240 volt use.

The Stereo 120 is designed for use with either 50 Hz or 60 Hz current.

## ASSEMBLY INSTRUCTIONS

### GENERAL ASSEMBLY INFORMATION

Assembly of the Stereo 120 is exceptionally simple when compared to other kits. The preassembled etched circuit boards have saved you much of the work, and the assembly that remains is arranged in an open, uncluttered layout that makes wiring quick and easy. The construction time will be only a few hours, but it is best to work slowly and carefully rather than worry about the time.

When you unpack your kit, check off the components against the parts list at the back of the manual. You can identify unfamiliar parts by matching them to the pictorial diagram or photograph.

Have the proper tools at hand before starting assembly. You will need a pencil-type soldering iron of 30- to 60-watt rating with a small tip, long nosed pliers, diagonal cutting pliers, a medium-sized screwdriver, and 60/40 *rosin core* solder not larger than  $\frac{1}{16}$ " diameter. You will also find a damp sponge or cloth helpful to wipe the tip of the iron clean periodically. An inexpensive wire stripping tool is helpful, but some people prefer a single-edged razor blade for removing the insulation.

If you have a soldering gun, it should be used with care, especially when working on the circuit boards. Not only can a gun provide more heat than is necessary, with some risk that an unskilled user might damage the board, but because it requires some time to heat each time the trigger is squeezed, many users tend to make poor solder connections simply because they do not wait long enough for it to reach its operating temperature each time.

You should realize that delicate components such as transistors are less likely to be damaged in the soldering process if you use a hot iron a short time, rather than a cooler iron for a longer period. You will also make a better connection with the hot iron. If you keep the iron clean by wiping the tip frequently, and occasionally add a small amount of solder to the tip, it will aid the transfer of heat to the connection. Do not allow too much solder to build up on the tip, though, or it may fall onto adjacent circuitry.

A good solder connection does not require a large amount of solder around the joint. A well-made connection looks

smooth and shiny because the solder *flows into the joint* when both parts are hot enough.

There are four steps to making a good solder connection:

1. Make a good mechanical connection.
2. Heat *both* parts with the tip of the iron *at the junction*.
3. Apply solder to the *junction* until it melts and flows.
4. Allow the connection to cool undisturbed.

**ALL SOLDERING MUST BE DONE WITH A GOOD GRADE OF ROSIN CORE SOLDER.**

Under no circumstances should acid core solder be used. Unmarked solder, cheap solder or any of doubtful origin should be discarded, and *separate solder fluxes should never be used*. The warranty is voided on any equipment in which acid core solder or acid type fluxes have been used. Silver solder is not suitable. The recommended solder is 60/40 (60% tin, 40% lead) **ROSIN CORE**. Do not confuse this with 40/60, which is harder to use.

When the instructions refer to "tinning" a wire, apply the iron to the bared wire end, and after a moment, touch the solder to the wire so that the solder lightly coats the wire. This makes it easier to get a good connection when the wire is inserted into an eyelet, for example.

Whenever one wire is to be soldered to a connection such as a lug or a transistor lead, the instructions will indicate this by the symbol (S). If more than one wire is to be soldered to the same point, the instructions will so state. If no symbol is shown, do not solder; further connections will be made to that point before soldering is called for.

Components such as resistors and capacitors are marked individually with their values, or with a color code. The color code will be given in the instructions when needed. The first color band on a resistor is the one nearest the end.

A number of steps begin, "Connect one end of a wire . . .", with the length of wire specified. In each case, first cut a piece of the correct color wire to the specified length, and then remove about  $\frac{1}{4}$ " of insulation from *each* end before making the connection. This is easiest with wire strippers, but diagonal cutters can be used if you are careful not to nick the wire and weaken it. With stranded wire such as transformer leads and line cords, be particularly careful not to cut the strands when stripping the ends.

## MECHANICAL ASSEMBLY

The position of all wire leads should follow the diagram and photograph closely, bearing in mind that the pictorial diagram has necessarily been distorted somewhat to show all connections clearly. See that uninsulated wires do not touch each other unless, of course, they are connected to the same point. It is especially important that uninsulated wires or component leads or terminals do not touch the chassis accidentally.

Check your work after each step. When you are satisfied that it has been correctly done, check the space provided and go on to the next step. Be sure you read carefully the explanatory paragraphs in the assembly instructions.

One of the best ways to make a good mechanical connection is to bend a small hook in the end of the wire, and then to crimp the hook onto the terminal lug. The amount of bare wire exposed need not be exactly  $\frac{1}{4}$ -inch, but if it is too long, the excess might touch another terminal lug or the chassis. Do not wrap the wire around the lug more than one time, as this makes the connection difficult to remove if an error is made.

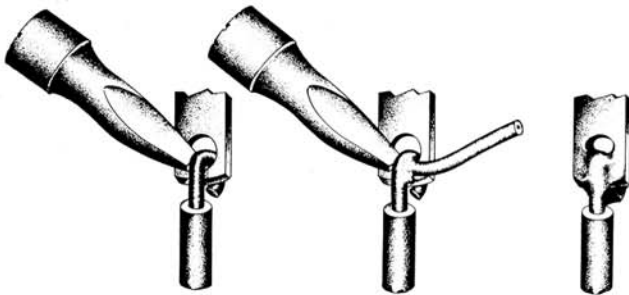
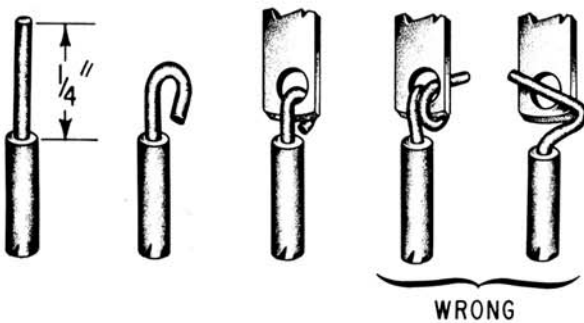

When soldering a lead to an eyelet on the circuit board, the Stereo 120 makes it easy to apply the iron to one side of the board while the tinned wire end is pressed into the solder-filled eyelet from the opposite side. When the eyelet is heated, the wire enters easily, but be careful that you *do not push the wire all the way into the eyelet up to the insulation*. If you do, you will not be able to see if you have made a secure connection, or if more solder is needed to provide a smooth flow from the wire, to the eyelet, and onto the circuitry on the board.

Although the Stereo 120 has an unprecedented number of safety devices which will prevent breakdown in use, only you can prevent breakdown resulting from improper construction. Transistor equipment, unlike much tube equipment, will not tolerate wiring errors, sloppy or incomplete soldering. **TAKE THE TIME TO BE NEAT AND ACCURATE**, and your amplifier will operate properly at first, and for many years to come.

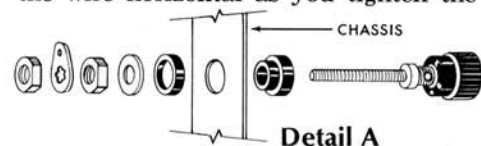
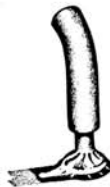

The three etched circuit boards and all of the 5 power transistors have been in-circuit tested before leaving the factory. This assures that all of the semi-conductors, as well as most of the other component parts, are performing to specifications. Only the interconnection of these parts is left to you.

There are 3 sizes of hardware — #4, #6 and #8. The #4 is the smallest, and the #8 the largest. The size used at each step is specified, and you should familiarize yourself with each. When #6 screws are called for, the  $\frac{1}{2}$  inch length should be used. The  $1\frac{1}{2}$ " #6 screws will be specified when they are used in the subassemblies. For your convenience, no #4 lockwashers are supplied. Use #6 lockwashers when #4 screws and nuts are called for.

- 1( ) Select four #6 screws, nuts and lockwashers and the four rubber feet. Insert the screws into the feet until the screw heads are entirely recessed within the feet. The fit is very tight, so you can invert the chassis and place the foot over a hole in the bottom, and then force the screw down. After the screws are inserted into the feet, mount the feet loosely on the bottom of the chassis in the round holes nearest the chassis corners. A lockwasher goes under each nut. Later, 3 of these feet must be temporarily removed when mounting the circuit assemblies, but installing them now will avoid damaging your work surface.
- 2( ) Install the 2 input sockets with #4 screws, nuts and lockwashers under the nuts. There is an inner "hot" connector and a shorter outer "ground" tab on each socket. Install each socket with the ground tab toward the outside as shown in the pictorial diagram.
- 3( ) Install the 2 black output binding posts in the lower holes next to each input socket. See Detail A. A shoulder piece goes outside the chassis with the smaller diameter portion protruding through the hole. The insulating plastic ring fits over it inside the chassis, followed by the washer. Before tightening the first nut, unscrew the outside knurled end and observe the hole in the metal shaft. For greatest convenience in connecting loudspeaker leads to these posts later, rotate the assembly so that this hole is in a horizontal position. Slip a piece of wire through the hole for easy observation as you tighten the first nut. Slide on the connecting lug, and fasten with the second nut. Position each connecting lug as shown in the pictorial diagram, and keep the wire horizontal as you tighten the second nut.

- 4( ) Install the two red binding posts in like manner in the upper holes. Keep the hole in the metal shaft horizontal, and note the correct lug placement in the pictorial diagram.

The next 5 steps describe the installation of the large capacitor mounting brackets. In each case, refer to the pictorial diagram for the correct placement of the clamp on the bracket, and also for the direction of insertion of the clamping screw. This will facilitate servicing access if required in the future. All mounting screws are installed from the outside (bottom) of the chassis, the capacitor bracket put in position, followed by a terminal strip if one is specified. Then use a lockwasher (or ground lug), and fasten with a nut. One #6 screw and nut referred to in each of these steps is to be installed *without a lockwasher* in the bracket *clamp* before mounting. Because the brackets are flexible, you will find that the capacitors will be most secure if they are temporarily slipped into each bracket for sizing as the bracket mounting bolts are tightened. While squeezing the bracket around the capacitor, tighten all the mounting bolts, starting first with the bolt farthest from the clamp. Then remove the capacitor. *Do not remove the outer insulation from any capacitor.*

- 5( ) With four #6 screws and nuts, two #6 lockwashers and the ground lug, install the largest diameter (2½") bracket for C12. Note the location near the center of the chassis of the ground lug which goes on one of the mounting screws.
- 6( ) With three #6 screws and nuts, and two lockwashers, plus the shorter of the two terminal strips, install the 1½" diameter bracket for C9 at the rear of the chassis. This is the middle size of those remaining. The terminal strip is installed on the screw nearest the rear of the chassis.
- 7( ) With three #6 screws and nuts, and two lockwashers, install the smallest diameter bracket for C11 on the right side of the chassis.
- 8( ) With four #6 screws and nuts, and three lockwashers, install one of the 2" diameter brackets near the center of the chassis.
- 9( ) With four #6 screws and nuts, and three lockwashers, plus the remaining (longer) terminal strip, install the second 2" diameter bracket at the front of the chassis. The terminal strip is installed on the front mounting screw adjacent to the binding posts.
- 10( ) Cut an 8" black wire. Connect one end to the right channel black binding post lug. Connect the other end to the ground lug on the C12 bracket in the center of the chassis.
- 11( ) Cut another 8" black wire. Connect one end to the left black binding post lug. Connect the other end to the ground lug on the C12 bracket.
- 12( ) Trim both leads of one 4.7 ohm resistor (yellow-violet-gold-silver) to ¾". Connect one lead to the right black binding post lug. Connect the other end to the adjacent lug #1 of the 2-lug terminal strip.
- 13( ) Trim both leads of one 0.1 mfd capacitor to ½". Connect one lead to the same lug #1 of the terminal strip. Solder the two leads to the lug. Connect the other end to the lug of the right red binding post.
- 14( ) Trim the leads of the remaining 4.7 ohm resistor (yellow-violet-gold-silver) to ¾". Connect one lead to the left black binding post lug. Connect the other end to the adjacent lug #2 of the 2-lug terminal strip.
- 15( ) Trim the leads of the remaining 0.1 mfd capacitor to ½". Connect one lead to the same lug #2 of the terminal strip. Solder the two leads to the lug. Connect the other end to the lug of the left red binding post.
- 16( ) Cut a 6½" black wire and a 7" green wire. Twist these together so that the wires are even at one end. The even ends will be connected now. Connect the black wire to the ground (short) lug of the right input socket. (S). Connect the green wire to the long lug of the right input socket. (S). These wires should project upwards from the chassis when they are soldered in place.
- 17( ) Cut a 3¼" green wire and a 3½" black wire. Twist these together so that the wires are even at one end. The even ends will be connected now. Connect the black wire to the ground (short) lug of the left input socket. (S). Connect the green wire to the long lug of the left input socket. (S). These wires should also project upwards when soldered.
- 18( ) There are two coils of heavy gauge insulated wire supplied in your kit. These are to be wound tightly around the 2" output capacitors C7 (right and left). To facilitate the forming of these coils and their installation, you will use a *smaller* electrolytic capacitor C9 (1000 mfd) as a form. To do this, strip one end of one of the coils ¼". Form a hook on this end, and engage the hook with either one of the lugs on the capacitor C9. Form two right angles, as shown in Detail B, so that the wire comes over the side of the capacitor and starts in a *clockwise direction* when looking at the top (lug end) of the capacitor. Wind the wire tightly, with the turns as close together as possible until all of the wire is used. You must hold the "start" while you wind. This is the most tedious part of the kit. Take the time to do a good job. When you release your hold, the wire will spring loose to form a larger diameter coil. Disengage the hook from the lug and slide the coil off. You will now install this coil on one of the two 2" diameter (3300 mfd @ 50 volts) capacitors C7. With the hook at the top, wind or guide the preformed coil onto this capacitor, one section at a time, as though you were threading it on. Patience will reward you with a neat job. With care, you can avoid deforming the coil and keep it snug. When the coil is all on the capacitor, slide it around so that it is convenient to engage the black capacitor lug with the hook and crimp the hook through the lug. Keep the turns snug.



**Detail B**

**Now turn to page 12**

## COMPONENT VALUES

All resistors are 1/2 watt, 5% unless otherwise specified.

		PART #		PART #	
R 1	4,700 ohms	113472	R21	1,200 ohms	113122
R 2	4,700 ohms	113472	R22	3,900 ohms,	
R 3	30,000 ohms	113303		1 watt, 5%	116392
R 4	150 ohms	113151	R23	1,000 ohms, 10%	112102
R 5	100,000 ohms	113104	R24	4,700 ohms	
R 6	1,000 ohms	113102		1 watt, 10%	115472
R 7	1,500 ohms	113152	R25	10,000 ohms	113103
R 8	270 ohms	113271	R26	22,000 ohms, 10%	112223
R 9	4,700 ohms	113472	R27	0.47 ohms	
R10	3,900 ohms	113392		2 watt, 10%	128004
R11	10,000 ohms	113103	C 1	5 mfd, 10v.	282505
R12	10,000 ohms	113103	C 2	150 pf mica	257151
R13	100 ohms	113101	C 3	250 mfd, 40v.	283250
R14	100 ohms	113101	C 4	35 mfd, 20v.	
R15	4,700 ohms	113472		non-polarized	283356
R16	300 ohms		C 5	250 mfd, 16v.	283251
	7 watt, 5%	120301	C 6	50 mfd, 10v.	282506
R17	300 ohms		C 7	3300 mfd, 50v.	283338
	7 watt, 5%	120301	C 8	0.1 mfd, 100v.	264104
R18	4.7 ohms		C 9	1000 mfd, 100v.	284108
	1 watt, 10%	125040	C10	50 mfd, 25v.	283516
R19	6,200 ohms	113622	C11	500 mfd, 100v.	284507
R20	1,000 ohms, 10%	112102	C12	3300 mfd, 100v.	284338

				PART #
Q 1	40233	100-250 Beta		572683
Q 2	2N3053	100-200 Beta, 90 V <sub>cer</sub> , r = 5KΩ		572670
Q 3	2N3053	100-200 Beta, 90 V <sub>cer</sub> , r = 5KΩ		572670
Q 4	2N4037	100-160 Beta, 90 V <sub>cer</sub> , r = 5KΩ		562671
Q 5	2N3055	17-25 Beta @ 3 A, 90 V <sub>cer</sub> , r = 200Ω		571844
Q 6	2N3055	17-25 Beta @ 3 A, 90 V <sub>cer</sub> , r = 200Ω		571844
Q 7	2N4037	100-250 Beta, 90 V <sub>cer</sub> , r = 5KΩ		564671
Q 8	2N3053	100-200 Beta, 90 V <sub>cer</sub> , r = 5KΩ		572670
Q 9	2N4347	8-16 Beta @ 3 A, 110 V <sub>cer</sub> , r = 200Ω		574844

D 1	silicon diode, 200 ma., 200 prv.	544012
D 2	silicon diode, 0.7 volt drop @ 100 ma.	544015
D 3	silicon diode, 0.7 volt drop @ 100 ma.	544015
D 4	silicon diode, 3 amperes, 200 prv.	544322
D 5	silicon diode, 3 amperes, 200 prv.	544322
D 6	silicon diode, 3 amperes, 200 prv.	544322
D 7	silicon diode, 3 amperes, 200 prv.	544322
D 8	silicon diode, 200 ma., 200 prv.	544012
D 9	silicon diode, 200 ma., 200 prv.	544012
D10	zener diode, 58 volt, 2%, 1 watt.	540158
D11	silicon diode, 200 ma., 200 prv.	544012
D12	silicon diode, 200 ma., 200 prv.	544012
T 1	Dynaco FA-704 power transformer	464001
S 1	DPDT lighted switch	334001
F 1	fuse 3 amp slo-blo	341030
F 2	fuse 1.5 amp slo-blo (alternate)	341015
L 1	74 inches of #16 insulated wire	311016

### VOLTAGE TEST POINTS

Measured with VTVM, 120 or 240 volt 60 cycle AC line, 8 ohm load, shorted input. All voltages are DC unless specified AC.

<i>Left PC-14</i>	<i>Right PC-14</i>	<i>PC-15</i>	
#1	72	#1	-21
#2	37	#2	-21
#3	<0.5	#3	72
#4	37	#4	72
#5	72	#5	71
#6	36	#6	0
#7	36	#7	-20
#8	36	#8	70 AC*
#9	71	#9	
#10	71	#10	71
#11	0	#11	0
#12	0	#12	0
#13	0	#13	0
#14	36	#14	37
#15	0	#15	72

\*Measured between eyelets located on circuit board edge

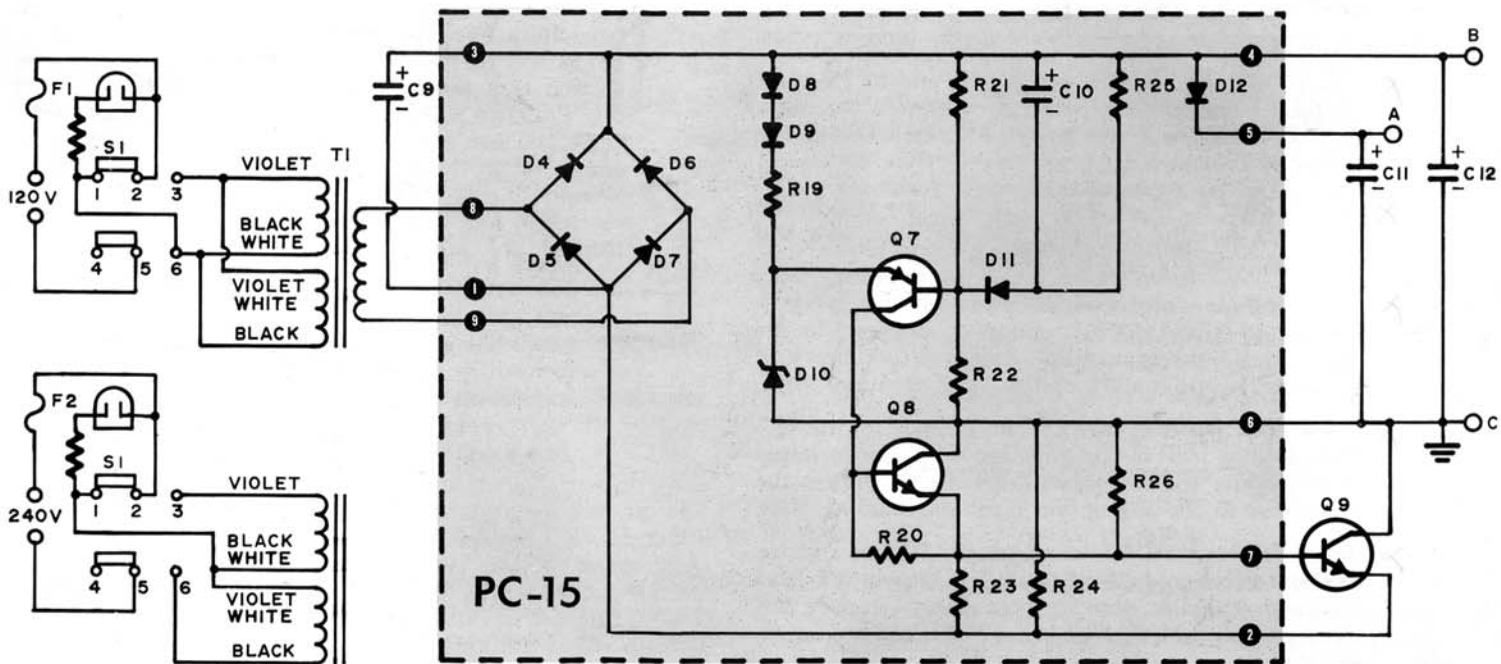

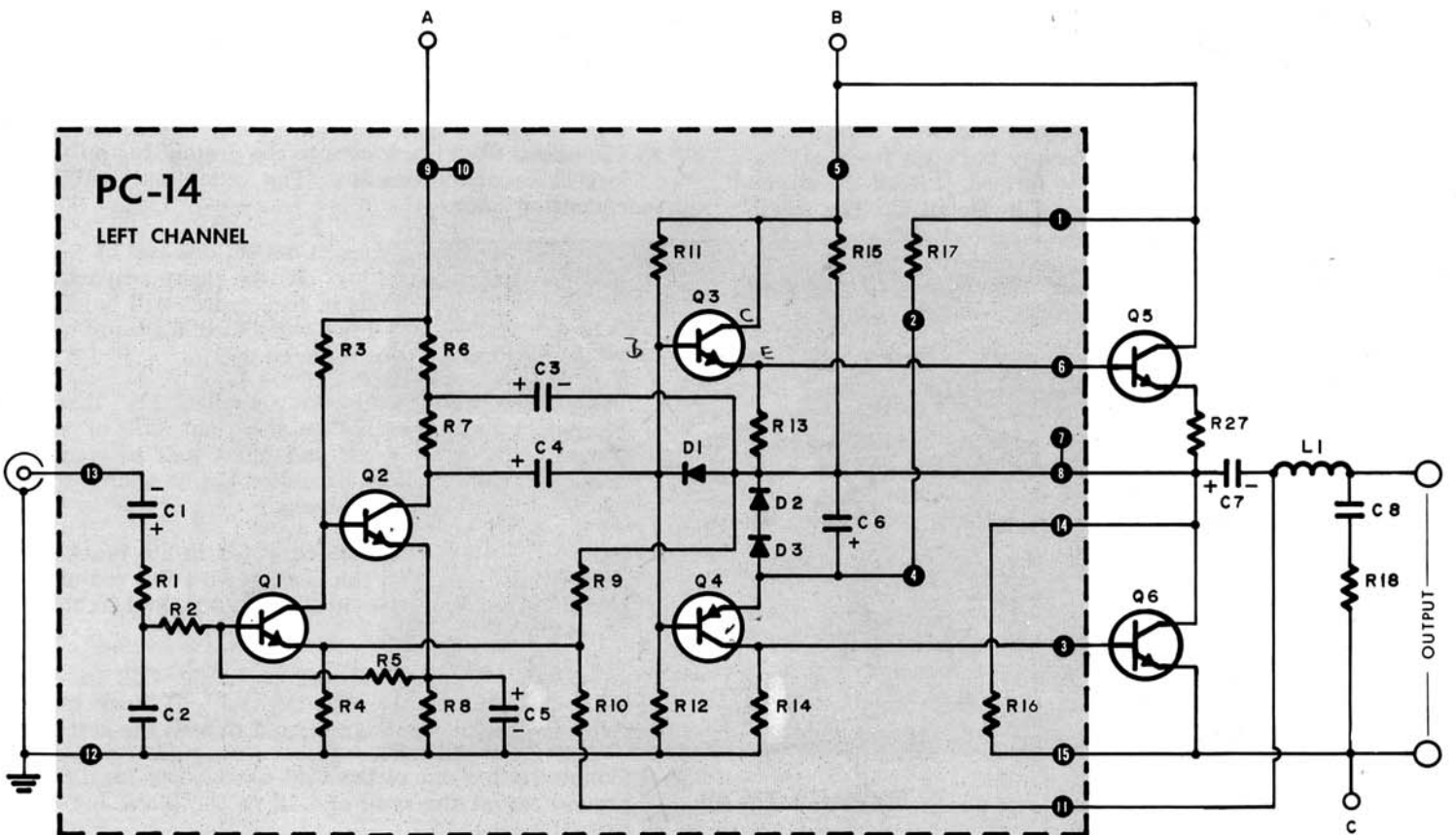
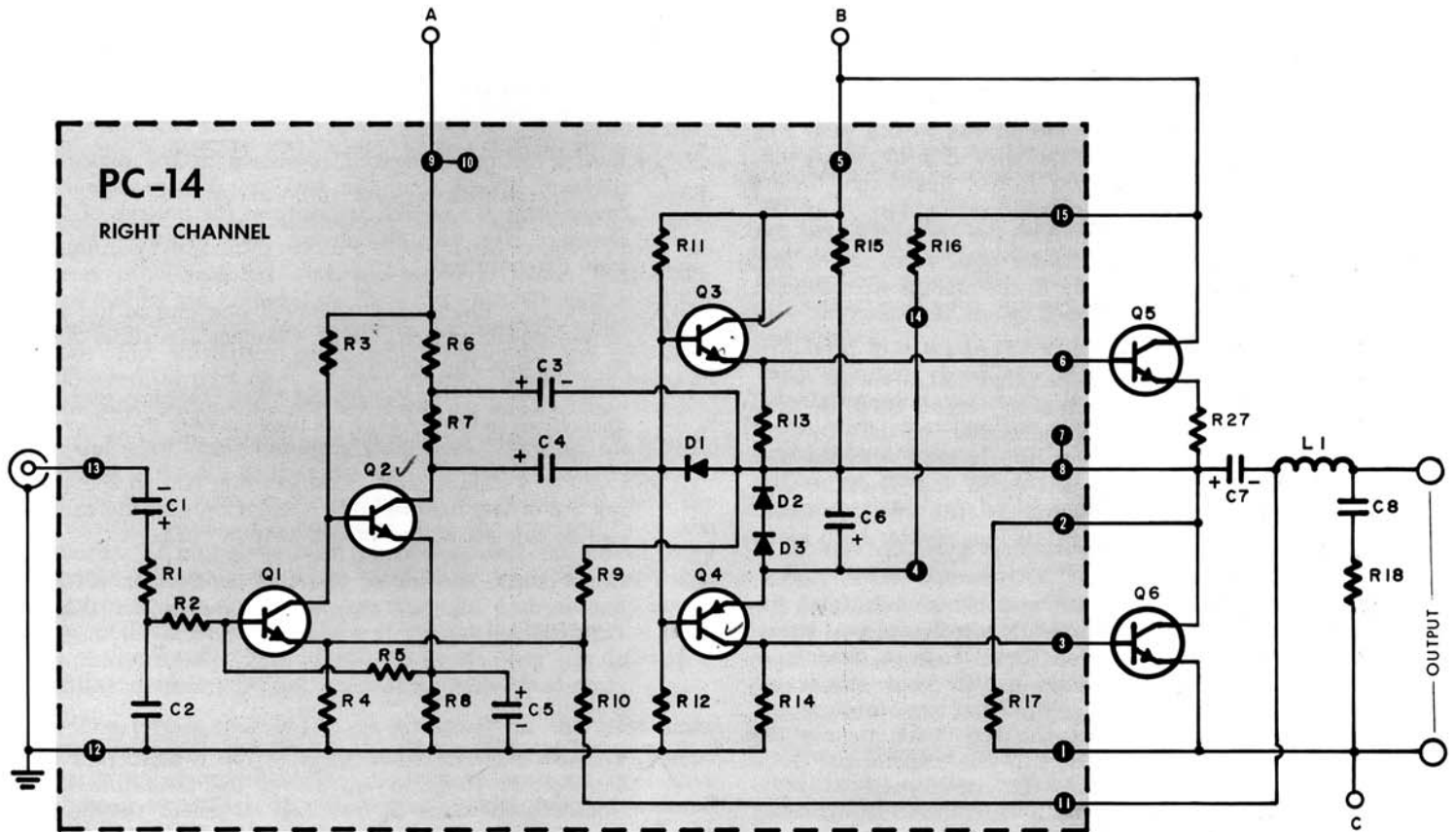

- 19( ) Form a second coil as above and install it on the other 2" diameter (3300 mfd @ 50 volts) capacitor.
- 20( ) Count 10 full turns on one of the coils just made, allow 1½" extra, and cut off the excess. On this end of the coil, cutting the wire at a 45° angle will aid connection. Strip off ¼" of insulation. Insert this coil-capacitor combination in the front 2" bracket. Connect the free end of the coil to the left red binding post lug. Solder both wires to the lug. Seat the capacitor firmly to the chassis with the red and black lugs positioned as in the diagram, and tighten the clamp.
- 21( ) Count 10 full turns on the other coil, allow 6" extra, and cut off the excess on a 45° angle. Strip the free end ¼". Install this combination in the other 2" bracket, seat it firmly to the chassis with the red and black lugs positioned as in the diagram, and tighten the clamp. Connect the free end of the wire to the right red binding post lug. Solder both wires to the lug.
- 22( ) Twist together the black and black-white, and the violet and violet-white leads of the power transformer FA-704. Position these leads in the recess at the rear of the chassis as you place the transformer on the chassis with these leads around the right rear corner, and the red leads nearer the center of the chassis. Be sure the transformer leads are not pinched. Fasten the transformer with the four sets of #8 (largest) hardware. Insert each screw from the bottom, place a lockwasher over the transformer foot, and fasten with a nut. Now you should also tighten the rubber foot under the transformer, but be careful that you do not deform it.
- 23( ) Separate the two conductors of the line cord for about 3". Cut off one inch of one of the conductors. Strip ¼" of insulation from each (unless the line cord was supplied with stripped ends). Mark the line cord 4" from the longer end with a pencil or pen. Bend the cord sharply back on itself at the marking so that a "V" is formed. Install the strain relief at the "V" as shown in Detail C. The small end of the strain relief is nearest the end of the wire. With heavy pliers, crimp the two halves of the strain relief together around the wire to partially form the wire before insertion. Now grasp only the larger diameter portion of the strain relief with the tips of the pliers, squeeze it fully closed, and insert the combination from the outside of the chassis into the cutout nearest the power transformer. The device can only be installed in the cutout one way, and will snap into its locked position when fully inserted.

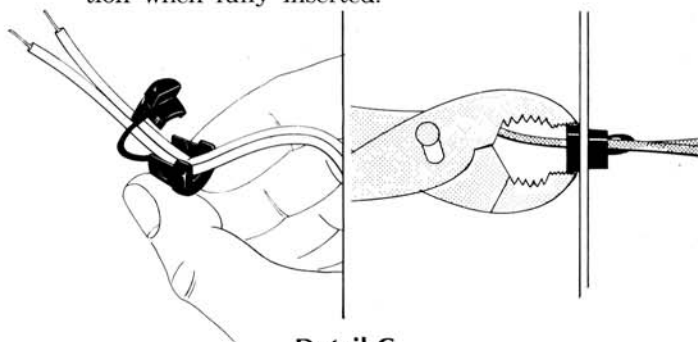

Detail C

- 24( ) Note the location of the connecting lugs on the fuse holder. Install it next to the line cord, with its rubber ring on the outside of the chassis. Fasten it with the lockwasher and nut inside the chassis.
- 25( ) Install the power switch as shown in the pictorial diagram. Note that the two small wires coming from inside the switch are nearest the bottom of the chassis. Use two #4 screws. No lockwashers or nuts are required.
- 26( ) Cut a 1¼" black wire. Connect one end to lug #1 of the power switch. (S). Connect the other end to lug #6 of the power switch.
- NOTE: If the amplifier is to be used with a 240 volt AC line, the connections for this step are as follows: Cut a 1¾" black wire. Connect one end to lug #1 of the power switch. (S). Connect the other end to lug #1 of the 2-lug terminal strip at C9.
- 27( ) Cut a 1½" black wire. Connect one end to the top lug #1 of the fuse holder. (S). Connect the other end to lug #2 of the power switch. (S).
- 28( ) Connect the shorter of the two conductors of the line cord to lug #2 (tip) of the fuse holder. (S). Connect the longer line cord conductor to lug #5 of the power switch. (S). Make certain that all strands of each conductor are soldered to the respective lug.
- 29( ) Connect the violet and violet-white twisted pair of transformer leads to lug #3 of the power switch. Solder both wires to this lug. Connect the black and black-white twisted pair of transformer leads to lug #6 of the power switch. Solder all three wires to this lug.
- NOTE: If the amplifier is to be used with a 240 volt AC line, the connections for this step are as follows: Solder only the violet transformer lead to lug #3 of the power switch, and solder only the black transformer lead to lug #6 of the switch. Twist together the black-white and the violet-white transformer leads and connect them to lug #1 of the 2-lug terminal strip. Solder all three wires to this lug. *Make certain that these wires are not connected to the same terminal strip lug which is bolted to the chassis!*
- 30( ) Connect a 6½" black wire to the ground lug on the largest capacitor bracket. The other end will be connected later.
- 31( ) Cut two 4½" black wires. Connect one end of each wire to the ground lug on the large capacitor bracket. The other ends of these wires will be connected later. Solder all five wires to this ground lug. *Be certain that all are soldered.*
- 32( ) Install the 500 mfd capacitor (smallest 1⅜" diameter) C11 in its bracket on the right side of the chassis. Position the red and black lugs as shown in the diagram, seat the capacitor firmly against the chassis, and tighten the clamp.
- 33( ) Install the 1000 mfd capacitor C9 in its bracket. Seat it firmly against the chassis with the red and black lugs positioned as in the diagram, and tighten the clamp.
- 34( ) Install the largest 3300 mfd capacitor C12 in its bracket, seat it firmly with the red and black lugs positioned as in the diagram, and tighten the clamp.
- 35( ) Connect either one of the 4½" black wires from the ground lug at the base of C12 to the black lug of capacitor C12. (S).

- 36( ) Connect the remaining 4½" black wire from the same ground lug at the base of C12 to the black lug of capacitor C11. (S).

### RIGHT CHANNEL SUB-ASSEMBLY

There are two similar sub-assemblies, each of which comprises a black aluminum heat sink with two pre-mounted transistors and a PC-14 circuit board (which has been pre-assembled and pre-tested). When these sub-assemblies are completed, they are each 60 watt amplifier channels with the exception of the output capacitor and coil. The third heat sink, which has only one transistor mounted, is part of the power supply. The other holes in this third heat sink are not used.

Use care when handling each part. Unwrap the circuit boards carefully so that the small finned radiators on some of the transistors on the boards do not catch and twist the transistor leads. Do not bend over the transistors on the boards. If any have been pushed against the board, they should be straightened so that their leads do not touch each other or any other components. Use care, however, because the small radiators are friction-fitted on the transistor bodies; if the radiators come off, they are difficult to replace without flexing the transistor leads.

The power transistors are mounted on the heat sinks with a special silicon grease which conducts heat readily, but is an electrical insulator. In case handling may have allowed some of it to get on leads which will be soldered to later, it is suggested that you carefully wipe off the transistor leads which protrude through the heat sink, and also the connecting lugs on all three heat sink assemblies. Be careful not to bend the transistor leads which protrude through the holes. When soldering to these leads, always make the connection at the *end* of the lead. See Detail D. Do not allow solder to flow into the recess formed by the hole in the heat sink.

While excessive heat may damage any transistor, the silicon types used in the Stereo 120 are very rugged, and it is more important that you have the transistor lead and the wire you are connecting to it hot enough before you apply the solder, so that the solder will flow quickly over the connection, giving you a smooth junction, without running down the lead into the recess. A small drop of solder on the tip of the iron will assist in heat transfer and good soldering. If the solder does not flow easily around the connection, allow the connection to cool, and try again after the tip of your iron is again hot.

There is a separate photograph showing the wiring to each amplifier heat sink, Detail E and Detail F, which identifies each transistor lead. The number adjacent to each wire identifies the step number. You may wish to mark the transistor leads on the heat sinks for quicker reference, and a soft pencil will be visible in good light, even on the black background.

In the following instructions you will be told to "form a loop". This requires that you first strip the standard ¼" of insulation from the wire (except resistor leads). Then with long nosed pliers, form a "U" or loop with the bare end of the wire. Slip the loop over the very tip of the transistor lead. When you crimp it in place with the pliers, it should hold to the lead while you solder it.

Neat wiring is *essential*. Observe on the photograph of each heat sink the direction each wire takes from its connecting point when you attach and solder the connection.

- 1( ) Place one of the amplifier heat sinks with the two transistors in front of you so that the transistor leads protrude toward you and the folded edge is at the bottom. Form a loop at one end of a 0.47 ohm resistor (yellow-violet-silver-silver) and crimp the loop onto the transistor lead Q5E. (S). Push the other end through the hole in lug Q6C.

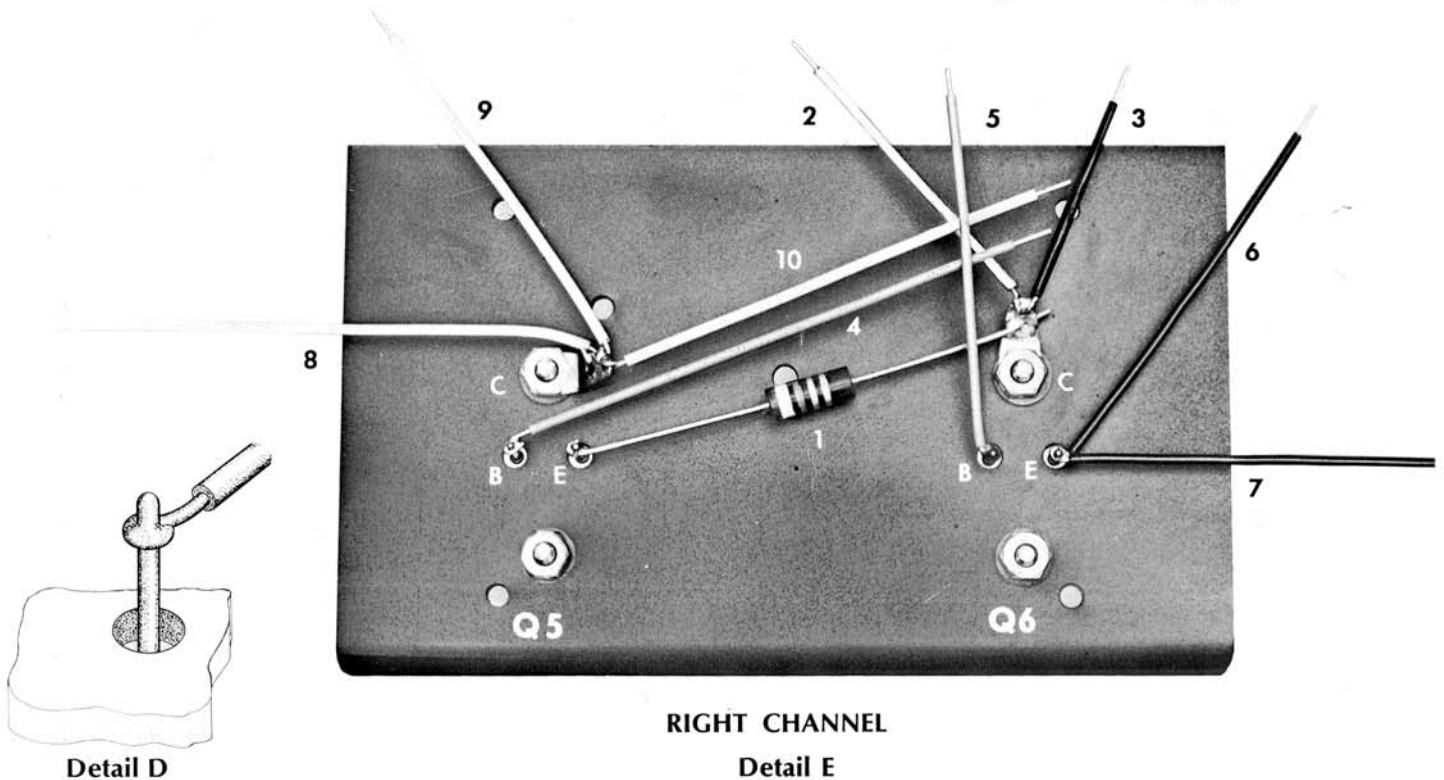

- 2( ) Cut a 2½" green wire. Connect one end to lug Q6C.
- 3( ) Cut a 2" black wire. Connect one end to lug Q6C. Solder all three wires to lug Q6C.
- 4( ) Cut a 4" green wire. Form a loop at one end and crimp it onto lead Q5B. (S).
- 5( ) Cut a 2¾" green wire. Form a loop at one end and crimp it onto lead Q6B. (S).
- 6( ) Cut a 3" black wire. Form a loop at one end and crimp it onto lead Q6E. Do not solder this yet.
- 7( ) Cut a 5½" black wire. Form a loop at one end and crimp it onto lead Q6E. Keep both of these wires close to the end of the transistor lead. Now solder both wires to lead Q6E. This requires some care to make sure that both wires are properly soldered.
- 8( ) Cut an 8¼" red wire. Connect one end to lug Q5C.
- 9( ) Cut a 2¾" red wire. Connect one end to lug Q5C.
- 10( ) Cut a 3½" red wire. Connect one end to lug Q5C. Solder all three wires to lug Q5C.

When soldering to the etched circuit boards, connections will always be made to eyelets which have solder in them. However, it will probably be necessary to use additional solder to assure a good connection from the wire to the eyelet, and to the circuit on the back of the board. The job will be easier if the tip of the iron is kept clean, and a small drop of solder on the tip will aid heat transfer. The wire will be easier to connect to the eyelet if the wire is first "tinned" (see soldering instructions).

Now is the easiest time to tin all of the wires connected to the heat sink assembly. As additional wires are called for, a convenient holder for them while tinning one end is the edge of one of the smaller corrugated cartons in which parts were packaged. This tinning will not be specified in each step.

When soldering to the eyelets on the board, all connections will be made to the back of the board (the circuit side, on which only the two large resistors are mounted on the PC-14s), unless the instructions specify a connection to the front. Touch the soldering iron to the opposite side of the eyelet as you insert the wire. Be sure the wire penetrates the eyelet as you move the iron aside. *Do not push the bared end of the wire all the way into the eyelet until the insulation touches the board.* If you do, you cannot be certain that you have a good solder connection from the wire to the eyelet to the circuitry on the board.

The large resistors on the back of each PC-14 have been deliberately mounted away from the surface for proper air circulation. Check to see that they are not touching the board.

Be particularly careful not to drop or flick solder onto the back of the circuit boards, as it might cause a short circuit between two conductors, causing damage when the amplifier is turned on.

- 11( ) Cut a 4½" red wire. Insert one end into eyelet #4 of one of the PC-14 circuit boards. (S). Insert the

other end into eyelet #14. (S). Position this wire below the row of eyelets, and clear of the board.

- 12( ) Insert one of the #6 x 1½" long screws in the hole in the heat sink above Q6 from the transistor side (outside). Slide a 1" tubular spacer onto the screw. Then place the PC-14 circuit board, with the etched circuit side (back) toward the heat sink and the numbered eyelets on top, on the screw and fasten loosely with a #6 lockwasher and nut. Use care in handling so you do not catch the finned radiators on the board and twist the transistor leads. Repeat the operation with the long #6 screws, nuts and lockwashers and 1" spacers at each corner of the board. Tighten all 4 nuts, but do not use excessive pressure.
- 13( ) Remove the rubber foot and hardware from the right front corner of the chassis, and set it aside.
- 14( ) Bring the right channel sub-assembly near its location on the chassis and connect the longer of the two black wires from Q6E (this is the longest black wire from the module) to the lug of the right black binding post. If you are not able to thread this wire through the hole in the binding post lug, it may be wrapped around the lug or around the bare resistor lead at this point. Solder all three wires to the lug.
- 15( ) Mount the right channel sub-assembly on the chassis, using the rubber foot and its hardware in the corner mounting hole, and a #6 screw, lockwasher and nut in the other mounting hole. Tighten both mounting bolts, but do not deform the rubber foot.
- 16( ) Insert the remaining short black wire from Q6E into eyelet #1. (S).
- 17( ) Insert the black wire from Q6C into eyelet #2. (S).
- 18( ) Insert the green wire from Q6B into eyelet #3. (S).
- 19( ) Insert the 3½" (middle length) red wire from Q5C into eyelet #5. (S).
- 20( ) Insert the green wire from Q5B into eyelet #6. (S).
- 21( ) Insert the green wire from Q6C into eyelet #7. (S).
- 22( ) Cut a 3½" green wire. Insert one end into eyelet #8 on the *front* (component side) of PC-14. (S). Connect the other end to the red lug of the *rear* capacitor C7 (right). (S).

No connection is made to eyelet #9 at this time.

- 23( ) Cut a 3¼" red wire. Insert one end into eyelet #10 on the *front*. (S). Connect the other end to the red lug of capacitor C11. (S).
- 24( ) Cut a 3½" green wire. Insert one end into eyelet #11 on the *front*. (S). Connect the other end to the black lug of the *rear* capacitor C7 (right). Solder both wires to this lug.

No connections are made now to eyelets #12 and #13.

- 25( ) Insert the short red wire from Q5C into eyelet #15. (S).

## LEFT CHANNEL SUB-ASSEMBLY

- 1( ) Place the other large black heat sink with two transistors in front of you so that the transistor leads protrude toward you and the folded edge is at the bottom. Cut a 5½" black wire, form a loop on one end, and crimp it onto transistor lead Q6E. Do not solder this yet.
- 2( ) Cut a 3¼" black wire, form a loop on one end and crimp it onto lead Q6E. Solder both wires to lead Q6E carefully.
- 3( ) Form a loop on one end of the remaining 0.47 ohm resistor (yellow-violet-silver-silver) and crimp the loop onto lead Q5E. (S). Push the other end through the hole in lug Q6C. Keep the resistor lead clear of Q5B.
- 4( ) Cut a 5" green wire. Form a loop on one end and crimp it onto lead Q6B. (S).
- 5( ) Cut a 2¼" black wire. Connect one end to lug Q6C.
- 6( ) Cut a 2¾" green wire. Connect one end to lug Q6C. Solder all three wires to lug Q6C.
- 7( ) Cut a 2¾" green wire. Form a loop on one end and crimp it onto lead Q5B. (S). Make sure the bared end cannot contact the resistor lead.
- 8( ) Cut a 4½" red wire. Connect one end to lug Q5C.
- 9( ) Cut two 2" red wires. Connect one end of each wire to lug Q5C. Solder all three wires to lug Q5C.

Now is a good time to tin all the free ends of the wires attached to the heat sink. Also remember to tin the ends of the wires following which are to be connected to eyelets on the board.

- 10( ) Cut a 2" red wire. Insert one end into eyelet #2 of the remaining PC-14 board. (S). Insert the other end into eyelet #4. (S). Position this wire so that it is clear of the board, and below eyelet #3.
- 11( ) Insert a #6 x 1½" long screw in the hole above Q5 from the transistor side of the heat sink. Slide a 1" tubular spacer onto the screw, and then place the PC-14 board, with the circuit side toward the heat sink and the eyelets on top, on the screw and fasten loosely with a #6 lockwasher and nut. Repeat this operation at each corner. Tighten all four screws, but do not use excessive force. Be careful of the transistors on the board.
- 12( ) Remove the rubber foot and hardware from the left front corner of the chassis, and set it aside.
- 13( ) Place the left channel sub-assembly near its location on the chassis, and connect the long black wire from Q6E to the lug of the left black binding post. If you cannot thread this wire through the hole in the lug, it may be wrapped around the lug, or around the bare resistor lead. Solder all three wires to this lug.
- 14( ) Mount the left channel sub-assembly on the chassis, using the rubber foot and its hardware in the corner hole, and another set of #6 hardware. Tighten the bolts but do not deform the foot.
- 15( ) Insert one of the 2" red wires from Q5C into eyelet #1. (S).
- 16( ) Insert the green wire from Q6B into eyelet #3. (S). This wire was earlier placed along the lower edge of the heat sink.
- 17( ) Insert the other 2" red wire from Q5C into eyelet #5. (S).

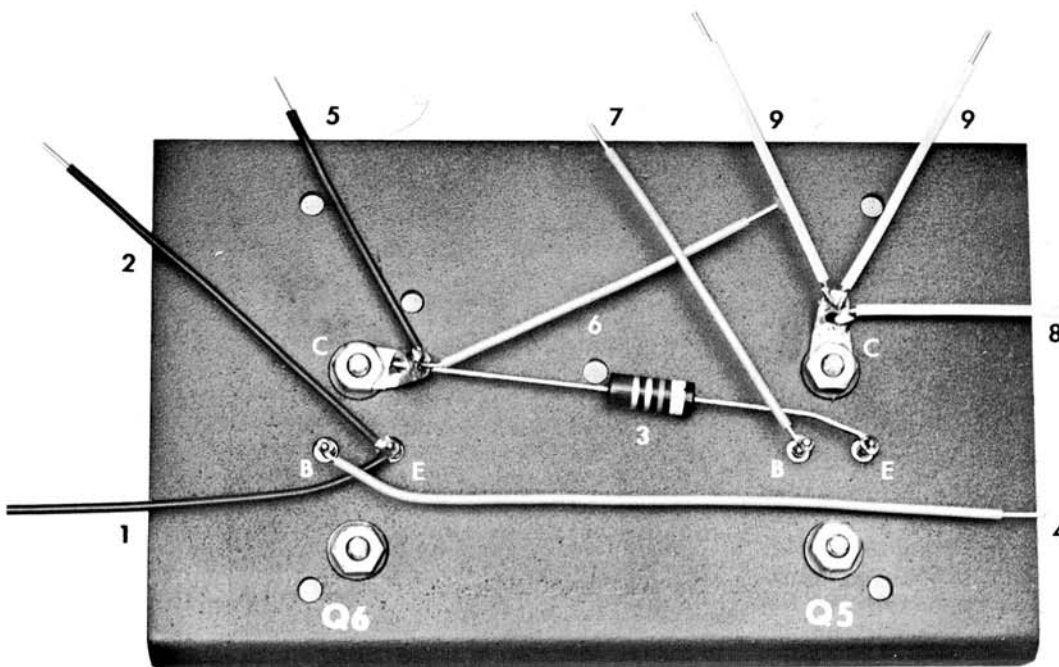

LEFT CHANNEL  
Detail F

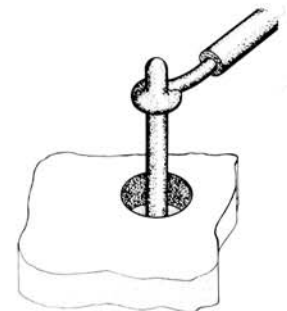

Detail D

- 18( ) Insert the green wire from Q5B into eyelet #6. (S).
- 19( ) Insert the green wire from lug Q6C into eyelet #7. (S).
- 20( ) Cut a 3¼" green wire. Insert one end into eyelet #8 on the *front*. (S). Connect the other end to the red lug of the *front* capacitor C7 (left). (S).
- 21( ) Cut a 6¼" red wire. Tin both ends. Insert one end into eyelet #9 on the *front*. (S). Insert the other end into the *front* of eyelet #9 on the *right channel* PC-14 board. (S).
- 22( ) Cut a 9" red wire. Tin both ends. Insert one end into eyelet #10. (S). The other end will be connected later.
- 23( ) Cut a 3¼" green wire. Insert one end into eyelet #11 from the *front*. Connect the other end to the black lug of the *front* capacitor C7 (left). Solder both wires to this lug.

No connections are made now to eyelets #12 and #13.

- 24( ) Insert the black wire from Q6C into eyelet #14. (S).
- 25( ) Insert the remaining black wire from Q6E into eyelet #15. (S).

#### POWER SUPPLY SUB-ASSEMBLY

The power supply module consists of the PC-15 circuit board and the remaining black heat sink with one transistor mounted.

- 1( ) Using the three remaining 1½" screws and 1" tubular spacers, mount the PC-15 board over the unused portion of the heat sink with #6 lockwashers and nuts. The circuit side of the board faces the heat sink. Be careful of the finned radiator on the board, and see that the mounting hardware does not touch it after it is installed.
- 2( ) Cut a 4" black wire. Form a loop on one end and crimp it onto lead Q9E. (S). See the pictorial diagram for identification of the leads, and for the general direction of the wire when it is being soldered.
- 3( ) Cut a 3¼" green wire. Form a loop on one end and crimp it onto lead Q9B. (S). See pictorial diagram.
- 4( ) Cut a 4" black wire. Connect one end to lug Q9C and crimp firmly in place. This is the wire from Q9C which will be connected to the circuit board eyelet later.
- 5( ) Remove the rubber foot and its hardware from the left rear corner of the chassis, and set them aside.
- 6( ) Twist together the two red leads from the power transformer. Place them in the recess at the bottom rear of the chassis, under the line cord, fuse holder, and power switch. Bring the power supply sub-assembly close to its location on the chassis, and solder either one of the red transformer leads to eyelet #8 from the *front* of the board. Heat the eyelet from the rear with the iron. Solder the other red lead to the *front* of eyelet #9. These eyelets are located on the side of PC-15. Be sure all strands of each lead are soldered to the spec-

tive eyelet. *Do not touch the black diodes, which are adjacent to the eyelets, with your soldering iron.* Be certain that sufficient solder has flowed from each lead to the eyelet and to the adjacent circuitry on the board for firm contact.

- 7( ) The long black wire which is connected to the ground lug on the C12 bracket should now be connected to lug Q9C. Solder both wires to lug Q9C.
  - 8( ) Mount the power supply sub-assembly on the chassis, using the rubber foot and its hardware, and another set of #6 hardware. Tighten the bolts, but do not deform the foot.
- Now is a good time to tin the 3 leads on the power supply assembly, before they are connected to eyelets on the board.
- 9( ) Cut a 2½" black wire. Insert one end into eyelet #1 of PC-15 from the *front*. (S). Bend over the black lug of capacitor C9 and connect this black wire. (S).
  - 10( ) Insert the black wire from Q9E into eyelet #2. (S).
  - 11( ) Cut a 2½" red wire. Insert one end into eyelet #3 from the *front*. (S). Bend over the red lug of capacitor C9 and connect this red wire. (S).
  - 12( ) Cut a 5" red wire. Insert one end into eyelet #4. (S). Connect the other end to the red lug of capacitor C12.
  - 13( ) Connect the free end of the long red wire which is attached to eyelet #10 of the left amplifier board to eyelet #5 of the power supply board. (S).
  - 14( ) Insert the black wire from Q9C into eyelet #6. (S).
  - 15( ) Insert the green wire from Q9B into eyelet #7. (S). Cut off this wire, and the wire to eyelet #6 close to the *front* of the board so that they cannot touch the adjacent finned radiator.

#### FINAL ASSEMBLY

- 1( ) Connect the long red wire from Q5C of the right amplifier module to the red lug of capacitor C12.
- 2( ) Connect the red wire from Q5C of the left amplifier module to the red lug of capacitor C12. Solder all three wires to this lug.

There are now only two twisted pairs of wires remaining to be connected. These have been left to the last so that they are not likely to be burned by a hot iron being applied to nearby eyelets. This is the time you should carefully check the connection to each eyelet on the 3 circuit boards. Check both the wire color and the "source" of that wire with the pictorial diagram. Look to see that there is sufficient solder at each connection flowing smoothly from the wire to the eyelet and to the circuitry for permanent contact. Wiggle each lead, and reheat the connection if the wire is not soldered securely. Do not leave large "balls" of solder around any eyelets. Look carefully to make sure that no solder has been dropped onto the board circuitry where it may cause a short circuit.

- 3( ) Position the black and green twisted pair of wires from the right input socket around the edge of the right amplifier board as in the diagram and photo-

graph of the amplifier. Keep these wires clear of the board, however. Tin each lead. Insert the black wire into the *front* of eyelet #12. (S). Insert the green wire into the *front* of eyelet #13. (S).

- 4( ) Position the black and green twisted pair of wires from the left input socket along the front edge of the left amplifier board, but away from the board. Tin each lead. Insert the green wire into the *front* of eyelet #13. (S). Insert the black wire into the *front* of eyelet #12. (S). Now recheck these connections, and those of the preceding step for a good, neat solder connection.

Assembly of the amplifier is now completed. Check to see that there are no unattached wires and no unsoldered connections. The short terminal strip near the power switch will not have any connections to its lugs unless the amplifier has been wired for 240 volt AC line operation. With a pair of diagonal cutting pliers, clip off any excessive stubs of wires to make a neat job. Pay particular attention to the power switch, so that there will be no possibility for leads to touch any but the correct lug. Also check the lugs on the 4 binding posts carefully, to see that none of those connections come close to the chassis.

Now turn the chassis over and shake out any bits of wire or solder. Insert the fuse in the fuse holder. Check to be sure that the power transformer leads will not interfere with the lip of the cover, and then the cover can be installed. The perforated metal edge stays inside the chassis as the cover is slid down over the chassis. Turn the unit over, and use four #6 screws to secure the cover through the slotted holes in the bottom.

If you have not already done so, read the "*Operating Instructions*" before turning the amplifier on. Remember to connect input and output leads to the amplifier before the power is turned on.

### IN CASE OF DIFFICULTY

Your Stereo 120 should function properly after assembly, but sometimes a wiring error, poor solder connection, or defective component may require trouble-shooting. Because 90% of the difficulties which are encountered in kit-built units can be attributed to incorrect wiring or a poor solder connection, it is strongly recommended that you ask someone else to check your wiring against the pictorial diagram, as frequently one person will make the same error twice.

Your Stereo 120 has been designed to provide exceptional accessibility for the serviceman, but the average kit-builder should confine his servicing to the basic suggestions given here, after checking to make sure the fuse is intact. Audio transistors, unlike tubes, cannot be easily checked locally for any other than gross defects, and even this should be left to the qualified technician. For this reason your Stereo 120 is considered to have "no user-serviceable parts inside".

The 3 modules (power supply and each amplifier channel) contain all of the semi-conductors (transistors and diodes). Each of the circuit boards and all 5 power transistors have been tested to assure that they meet specifications prior to shipment, so routine trouble-shooting can eliminate these as the source of the trouble, although they could have been subsequently damaged. You should, however, examine the back of each circuit board closely to make sure there are no solder splashes, and be sure that

no solder has been allowed to flow into the holes around the leads of the power transistors mounted on the heat sinks.

Check the connections at each eyelet along the edge of the circuit boards. Sometimes a connection which appears solid between the eyelet and the wire will not have a smooth flow of solder from the eyelet to the circuitry on the board. If a vacuum tube voltmeter is available, you should check each eyelet against the voltage chart on the schematic diagram. A deviation greater than 10% indicates a possible error or component failure.

Little or no audio signal from both channels usually indicates that the power supply is not functioning. If the 4700 ohm, one watt resistor R24 is overheating, the power supply is not "turned on" because of an excessive load or high input signal level. In the latter case, reducing the level of the input signal before switching on the amplifier will restore normal operation. An excessive load may be the result of improper output connections, or a fault in one of the amplifier modules.

You may be able to isolate a fault in one amplifier channel by removing the wire to one of the modules from the red lug of the largest capacitor C12. *Turn off the amplifier before you make or break any connections.* If the other channel then functions normally, the disconnected module is suspect.

In the event of difficulty with one of the channels, the suspect module (circuit board and attached heat sink) can be removed easily and returned to Dynaco for test and service, while the rest of the amplifier continues to function monophonically. For safety, 6 of the 8 leads from the module should be disconnected at the "far end" so that no unattached leads will be left in the amplifier. If you wish, the leads may be unsoldered at the module and insulated with electrical tape. Note that the test points (eyelets) #9 and #10 on each amplifier board are joined on the board, and when one module is removed, it is essential that the 2 wires connected to these points be unsoldered *at the eyelets* and temporarily soldered together to complete the circuit of the remaining amplifier. This connection must be insulated. Tag each wire for easy re-installation.

Because the module is light in weight, it may be shipped by air if desired. Do not return the circuit board alone—only the complete module. Be sure the packing adequately protects the small transistors with the finned radiators located on the circuit board, so that their leads will not be crushed. In extreme cases, it is possible to return all 3 modules for factory checking to save the weight of the chassis, power transformer and capacitors, but this is not recommended unless you are certain that no fault exists in these components, because the only sure test is that of the complete amplifier.

If you have a voltmeter, the power transformer can be checked by measuring the AC voltage between eyelets #8 and #9 on PC-15. A defective rectifier or poor solder connection on the rectifier bridge may cause the power transformer to emit an audible mechanical vibration. The DC voltage measured across C9 will be between 80 and 100 volts if the bridge rectifier diodes are functioning properly.

Beyond the most rudimentary checks, servicing of transistorized equipment should be left to the qualified technician. The Stereo 120 needs no maintenance in normal use, and there are no adjustments required during the life of the amplifier. Improper servicing can impair its performance or damage it, so it is very important that the technician familiarize himself with the Circuit Description and

with the Service Information which follows, before proceeding. Unless you are confident that a local repairman has the specialized knowledge and equipment for servicing high quality solid state audio equipment, *factory service is strongly recommended.*

### SERVICE INFORMATION FOR THE TECHNICIAN (FOR QUALIFIED PERSONNEL ONLY)

Before attempting to service the Stereo 120, be sure to read the circuit description in the front of this manual, as well as the preceding section, "In Case Of Difficulty". Some of the amplifier's unique features are not immediately apparent when examining this essentially simple circuit. A systematic check of voltages and signal paths, based on an understanding of the functioning of each section, will lead to a rapid diagnosis of any malfunction.

Each of the four screws which secures the cover is located between a rubber foot and the edge of the chassis. All of the numbered test points are located along the edges of each circuit board. Each of the three modules (power transistor heat sink and the associated circuit board) are fastened with only two screws. When these are removed, the module may be tilted outwards to gain access to the components.

There are three parts to the circuit. One is the regulated power supply. The other two are essentially identical audio amplifiers (but with changed physical layout). Capacitors C9, C11, and C12 provide power supply filtering and decoupling; and there is an output coupling capacitor C7 for each channel.

There are certain general precautions to be observed in servicing any transistorized equipment:

1. Never make circuit changes (connections or disconnections) of any kind when the amplifier is turned on.
2. Be particularly careful not to short any transistor leads to each other or to the chassis when the power is on.
3. When using test equipment, you must avoid transient voltage peaks and excessive test voltages.
4. Exercise caution when soldering and unsoldering transistor and diode leads to avoid excessive heat.

### Power supply

The power supply is designed to provide a constant 70 to 72 volts with demands up to 3 amperes and with power line voltages between 110 and 130 VAC (between 220 and 260 VAC when connected for 240 volt use). Transistor Q9 is a series regulator using servo-type action in which the impedance of Q9 is varied as the load changes to provide a constant output. This variation is accomplished by a negative feedback loop which compares the potentials at the emitter and base of Q7. Differences furnish a corrective signal which is amplified in Q8 and passed to Q9. Zener diode D10 furnishes a reference potential at the emitter of Q7, and a voltage divider at its base provides the comparison voltage. D10 is kept "alive" by the current flow in R19. However, when the current in Q7 exceeds the current in R19, D10 is "starved", and its Zener action drops out. Then, without a corrective signal, a regenerative action causes the supply to cut off by increasing the impedance of Q9 so that it cannot pass current.

### Amplifiers

There is a physical change of component positions for the left and right audio channels, but they are electrically identical. Each amplifier has two basic sections. The direct-coupled pair Q1 and Q2 is the Class A amplifier-driver with a DC feedback loop from the second emitter to the input base. Audio signals at the input base of Q1 are amplified and appear at the collector of Q2 to drive the four-transistor Class B power output section.

Q3 and Q4 are a complementary-symmetry driver directly coupled to Q5 and Q6 output power transistors. The Class B section provides a power gain, but no voltage gain. The input junction of Q3 and Q4, and the output junction of Q5 and Q6 swing together through the signal cycle. The ability of the output junction to follow the input junction (and the consequent linearity of this section) depends on the feedback path from the collector of Q6 to the emitter of Q4. Variations at Q4 emitter compared to its base potential will create a corrective signal for Q6, which makes the output follow the input.

Diodes D2 and D3 are in this feedback path, in a direction which would not be conductive (breaking the feedback path) were it not for the forced current through bleeder resistors R16 and R17. When the current in Q4 reaches that in R16 and R17, the diodes D2 and D3 no longer conduct, and the feedback path is broken. Simultaneously D1 starts conducting and makes a short circuit between the input of Q3 and Q4, and the output of Q5 and Q6.

Thus when the current demand in the feedback loop exceeds the limit determined by the bleeder resistors, the ability of the circuit to drive is restricted, and excessive currents cannot be induced in Q5 and Q6. The action of D1 short circuits the drive from Q2, reducing the drive until the cause of the high current demand is corrected. Thus an excessive drive signal, or too heavy a load on the output, which would require excessive current, switches the circuit to a configuration which prevents damaging current flow through the output and driver transistors.

### Trouble shooting the power supply

When the supply is performing properly, its voltage in a given amplifier remains within 1% of its nominal value over the operating range, and should be within 5% of the specified 72 volts. If the output is 80 volts or more, Q9 is probably shorted. Tests for gross transistor defects are described in a later section. An output of less than 65 volts indicates that the supply is either deficient or being overloaded. Turn off the amplifier and detach the wires to each of the amplifier modules at the positive terminal (B) of C12 so that the amplifier sections will be separated from the power supply. If normal supply voltage is obtained with these wires detached, then connect one amplifier lead at a time to see if one channel is loading the supply excessively.

Verifying the supply's performance under full load and under heavy load, as well as checking the 72 volt output, is necessary to assure normal supply operation. A suitable full load test can be made by connecting a 200 watt, 25 ohm resistor across the supply. This provides about 2.8 amperes current drain. The voltage output of the supply should not vary more than  $\pm 1$  volt. With a heavy load of 5 ohms, or even a short circuit, the current delivered should not exceed 0.5 ampere.

A low supply voltage when the (B) connections to the amplifiers are removed is most likely caused by a transistor which has failed, if the DC voltage across C9 is between 80 and 100 volts. All three power supply transistors should then be checked.

### Trouble shooting the amplifiers

Any signs of scorched resistors or wire should be a basis for further investigation. If either R13 or R14 is burned, or smokes when the amplifier is on, then at least one of the transistors Q5 or Q6 and possibly Q3 or Q4 has been damaged, and replacement will be required. It must be emphasized that *if one of the transistors in the Class B section (Q3, Q4, Q5, Q6) is defective, the other three must be tested before proceeding further* to avoid possible repetitive breakdown. Resistors R16 and R17 on the back of each board normally get hot because of the reference bleed current. If only one of the pair is hot, Q5 or Q6 may be shorted, or D2 or D3 may be open.

The voltage at the positive terminal of C7 should be about 36 volts (one half of the supply voltage). If this voltage is far off value, this can be a sign of trouble in one or more of the Class B transistors, and all should be checked.

If the voltage at the input bases of Q3 and Q4 is significantly different (more than 1.5 volts) from the voltage at C7, the voltage at the other end of C4 should be checked to determine if something is wrong in the Class A section, Q1 and Q2. A fault in either of these transistors can change the voltage at the collector of Q2 (input of C4), and this can be reflected in an incorrect potential at the bases of Q3 and Q4, which is further reflected in the junction of Q5 and Q6 (the positive terminal of C7). Voltages at either end of C4 may be inter-related when C4 is in the circuit. If one end of C4 is lifted, the voltage deviations from normal at either end will indicate whether a fault lies before or after C4.

It is unlikely that all voltages in the audio section are correct if there is no signal. However, if this condition occurs, it is most likely an open input capacitor C1, or coupling capacitors C4 or C7, or a shorted C2.

A signal which has some distortion, or is limited in power output, is more difficult to diagnose. See the section relating to performance tests. This requires a distortion analyzer and an oscilloscope to check the signal, and then routine signal tracing should locate the fault.

A very weak signal usually indicates that the power supply is shut down as a result of an excessive input signal or an excessive load. In this case R24 will be quite hot.

### Checking transistors

An ohmmeter is all that is required to locate a transistor which has failed. Small transistors must be removed from the circuit board for test. The power transistors need not be removed from the heat sinks, but the wires to their terminals must be detached for measuring. All transistors can be considered (for this test procedure) to be two diodes connected in series with common elements tied together. The junction point represents the base of the transistor. The identification of the larger power transistors is shown in the photograph of each heat sink. The smaller ones, observed from the bottom, have the collector, base and emitter arranged counter-clockwise, with the collector attached directly to the case.

With one ohmmeter probe connected to the base, the other probe should be touched to the collector and emitter in turn. Readings from the base to the collector, and from the base to the emitter should be similar. With one orientation of the probes, there should be a high resistance reading (almost an open circuit). When the polarity of the probes is reversed, there should be a relatively low reading. The high reading will appear with one orientation of the probes for a pnp transistor, and with the opposite orientation for an npn transistor. Then the ohmmeter should be connected from collector to emitter, and a high resistance (almost open circuit) should be read, regardless of the orientation of the probes. If all of these qualifications are met, the transistor does not exhibit any gross defects. Qualitative evaluation of acceptable transistors requires equipment beyond the scope of local service facilities.

In similar fashion, diodes can be checked by verifying that they have a high resistance in one direction, and low resistance in the other.

When replacing transistors, the small ones with the finned radiators should have the radiators transferred to the replacement. The silicon grease between transistor and radiator should be transferred to the new transistor. Be careful to insert the leads into the proper eyelets. Do not use excessive heat on the leads—let the heat go to the eyelet instead. When replacing the power transistors on the heat sinks, maintain the mica insulator between the transistor and the heat sink (Q9 does not use a mica insulator). Spread some of the silicon grease, which is a heat transfer compound, between the mica insulator and the transistor, as well as between the heat sink and the insulator. Be sure to use the nylon insulators around the mounting screws.

When making replacements, standard types can be used provided they are screened beyond the manufacturer's routine specifications. This is necessary because transistors of a given type vary far more widely than do tubes. The requirements for each transistor are given in the parts list with the schematic diagram. No screening will be necessary for transistors obtained from Dynaco if the application (Q-number) or the Dynaco part number is specified. If emergency needs require substitution of an unscreened transistor, the audio circuits will function but the effectiveness of the protective circuitry in the power supply may be somewhat reduced. The Dynaco audio circuit has been designed so that no matching of transistors is required.

While the parts list does not show all of the possible transistor options, under no circumstances should unlisted transistors be used unless factory-approved in advance.

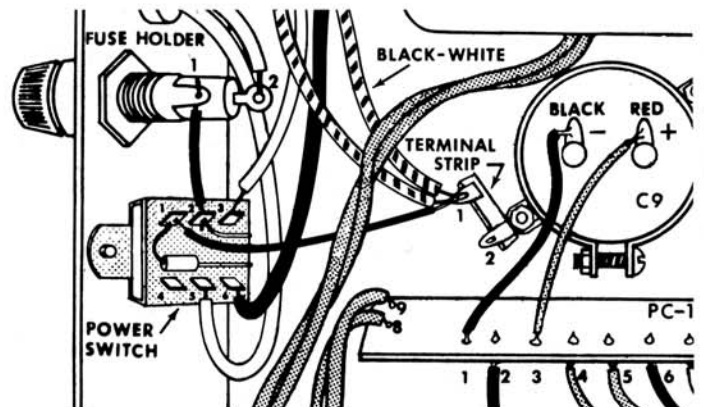

WIRING FOR 240 VOLT AC LINE

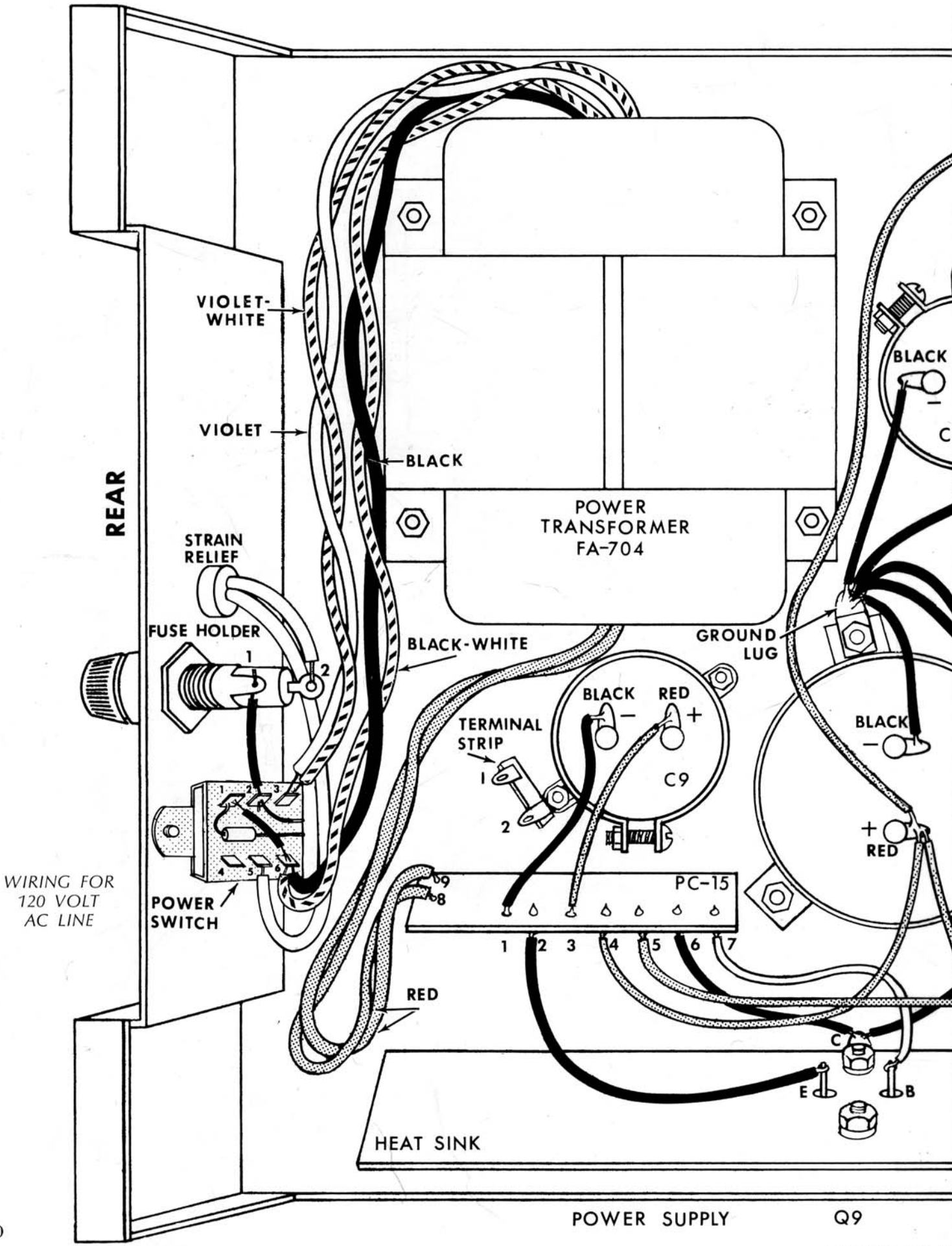
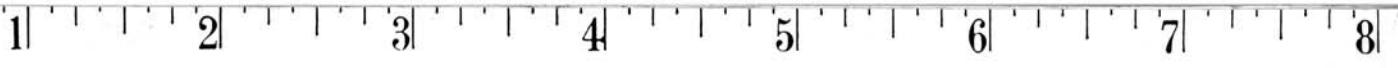

WIRING FOR  
120 VOLT  
AC LINE

REAR

VIOLET-  
WHITE

VIOLET

BLACK

POWER  
TRANSFORMER  
FA-704

STRAIN  
RELIEF

FUSE HOLDER

BLACK-WHITE

GROUND  
LUG

TERMINAL  
STRIP

BLACK RED  
- +  
C9

BLACK  
-

+  
RED

POWER  
SWITCH

PC-15

RED

HEAT SINK

POWER SUPPLY

Q9

PICTORIAL

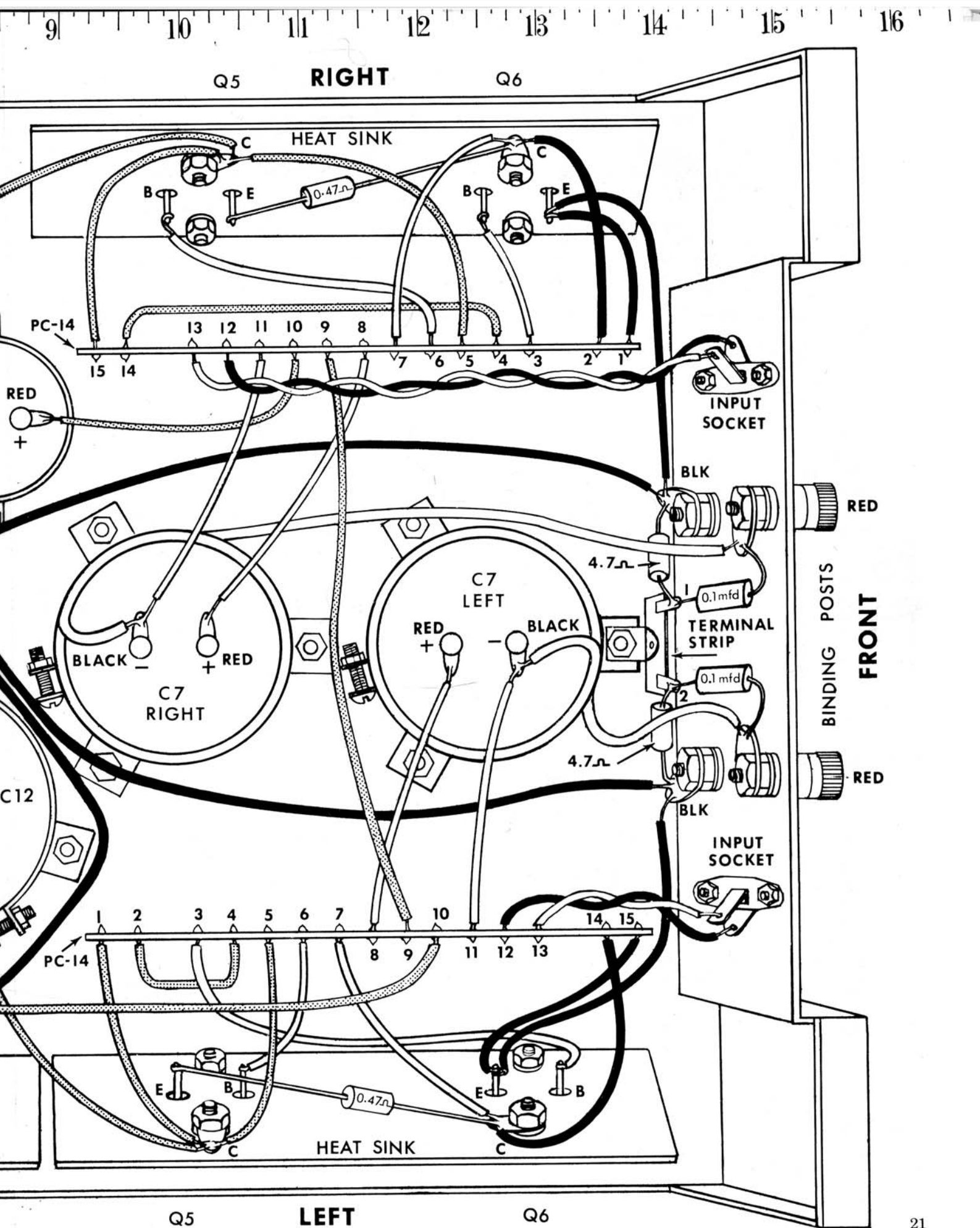

DIAGRAM

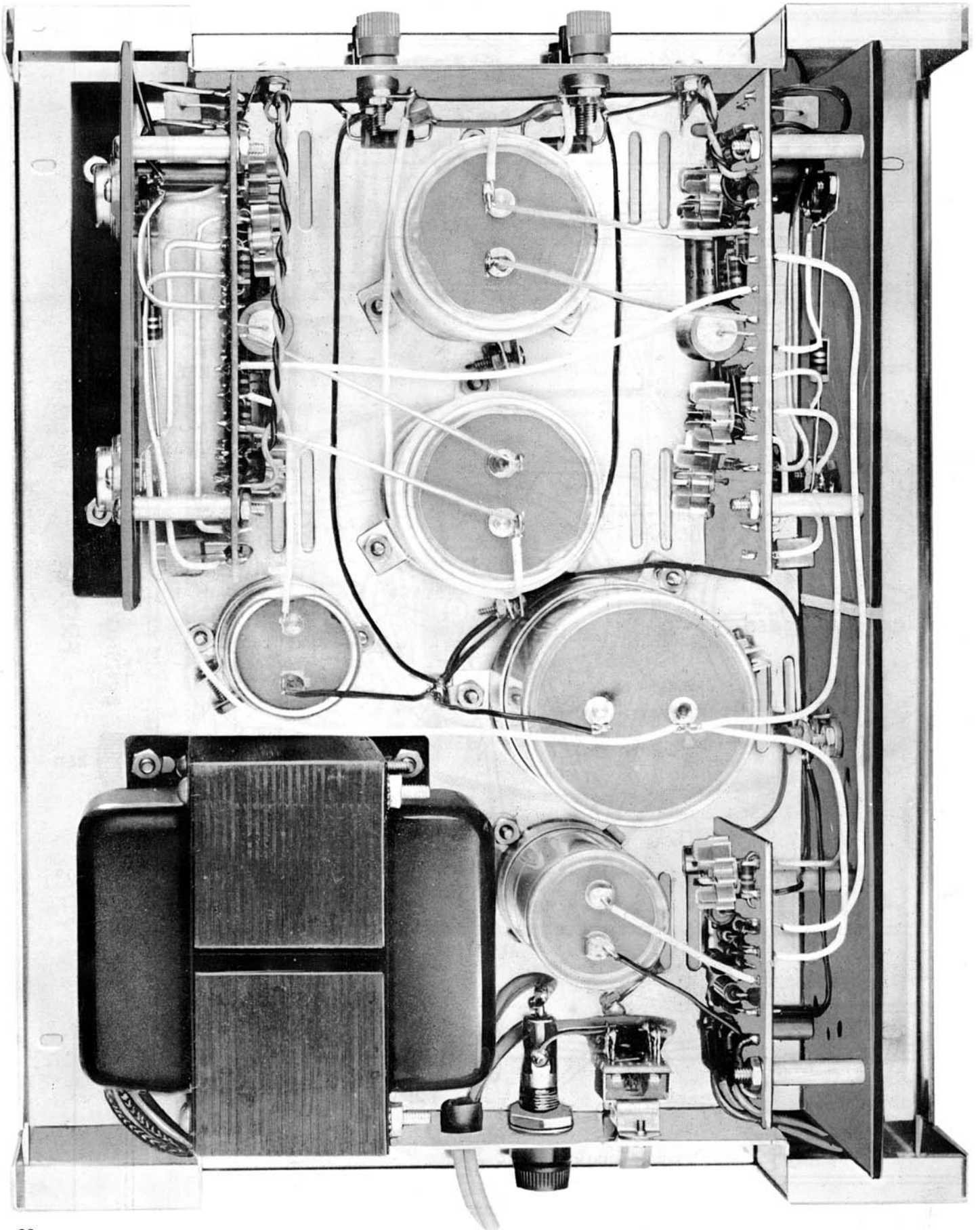

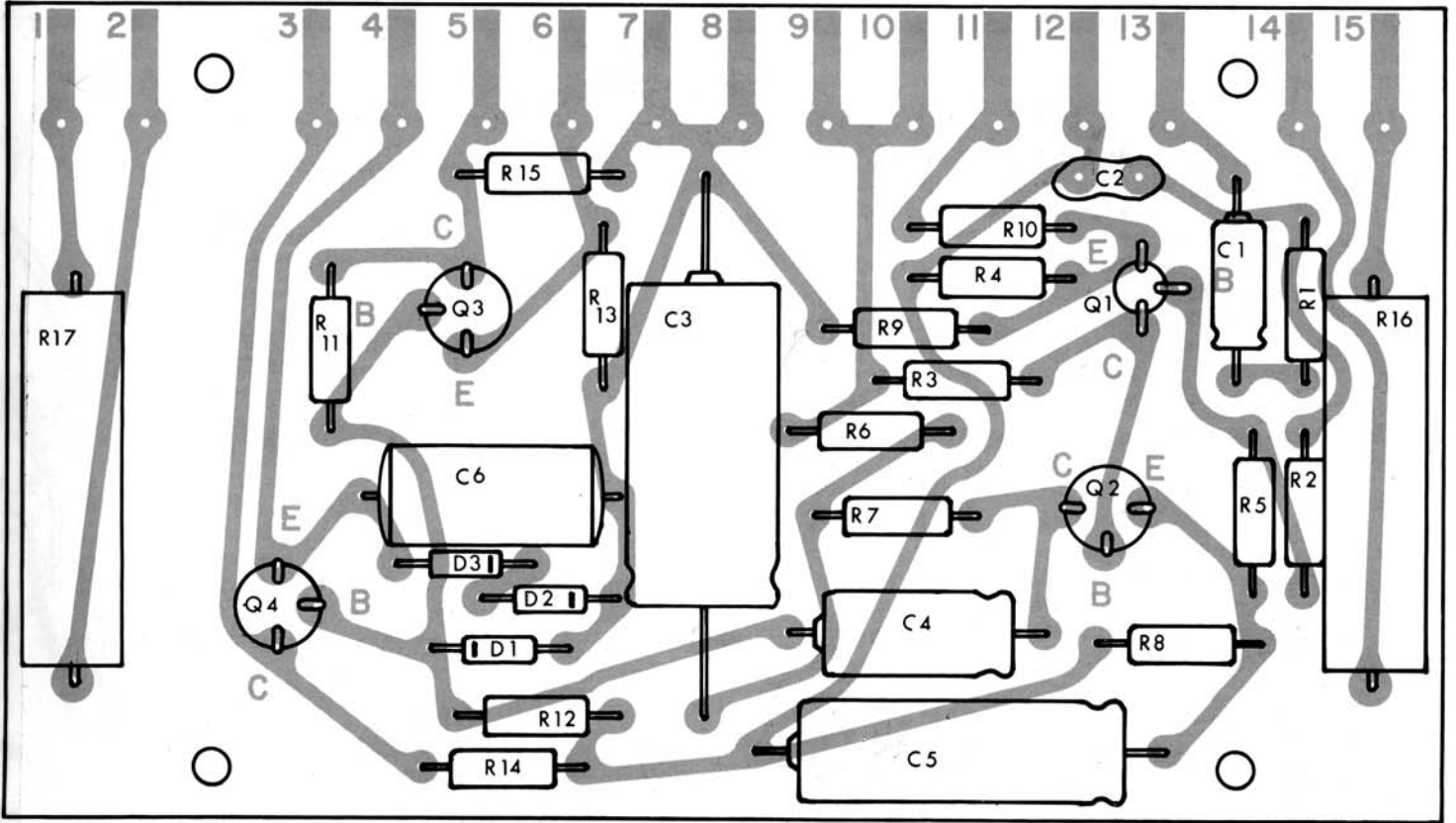

AMPLIFIER CIRCUIT BOARD

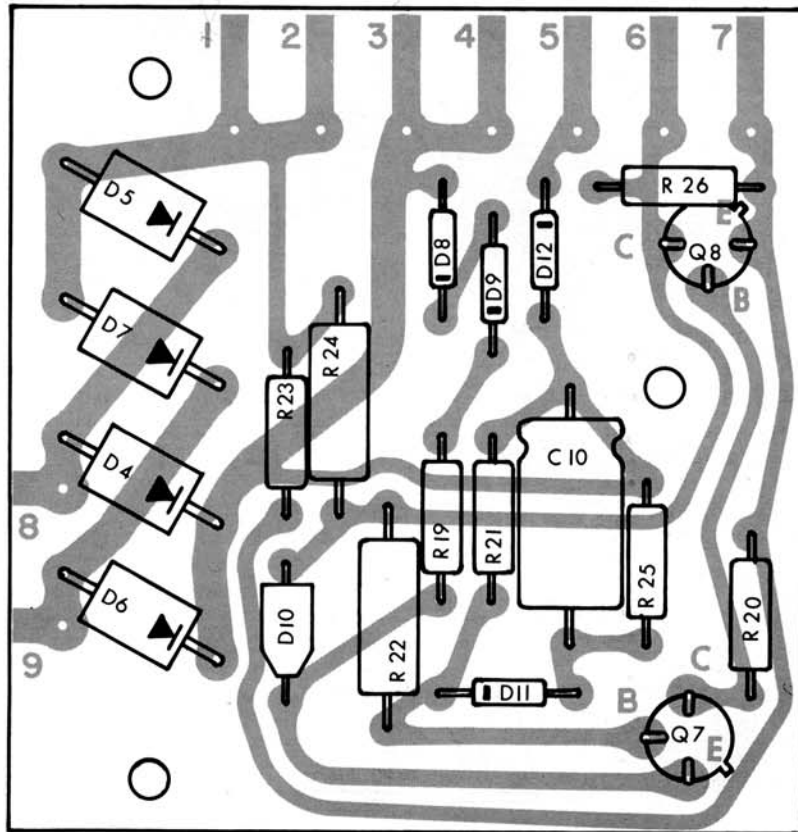

POWER SUPPLY CIRCUIT BOARD

## FACTORY SERVICE AND WARRANTY

The Stereo 120 has been designed to provide reliable, trouble-free operation for a long period of time when it has been properly assembled and installed. It incorporates unprecedented circuit protection against failure caused by abnormal operation. So conservative is its design that it will deliver unchanging performance with the maximum variations in AC line voltage (110 to 130) permitted in normal use.

Despite these precautions, service may sometimes be needed, and you should be sure to return the Guarantee Card promptly to validate your warranty. Dynaco maintains a complete factory test and repair facility for which no return authorization is required. Unless specifically authorized in advance by the factory, Dynaco cannot assume any responsibility for local service charges.

A factory assembled Stereo 120/A is warranted to be free of defects in materials and workmanship for a period of one year from the date of purchase. During the warranty period, no charge will be made for testing or servicing any defective factory assembled Stereo 120/A returned to Dynaco.

All parts used in a Stereo 120 kit are warranted to be free of manufacturing defects for one year from the date of purchase. Defective parts will be replaced promptly at no charge upon receipt for inspection at the factory. After the warranty period has passed, Dynaco will supply any non-standard parts at net prices. Standard parts can generally be obtained from a local electronics supply store.

The guarantee does not apply to other than the original purchaser, nor to units which have been subjected to neglect, abuse, misuse or accident.

If you suspect a defect in the power transformer, the leads must be unsoldered, not cut for its return. The warranty on the transformer is void if the leads have been cut too short for re-use.

If the kit has been completely assembled, yet does not function properly, or if difficulty develops after some use, Dynaco will service the Stereo 120 for a maximum charge of \$15.00. After one year, assembled units and kits are subject to the same charge, plus the cost of parts.

As described elsewhere in this manual, the modular design of the Stereo 120 enables individual sections to be returned for factory test and service. The service charge for each module will be a maximum of \$7.50, plus the cost of out-of-warranty parts.

Once a complete Stereo 120 has been serviced by Dynaco for which a regular service fee was charged, a 90 day service warranty is given. No service warranty can be extended for individual modules.

Factory service is not available for kits which are incompletely wired, or kits wired with other than rosin core solder, or units physically or electrically modified or used contrary to the *Operating Instructions*, without prior factory authorization.

Technical assistance which may facilitate local diagnosis or service is available at no charge. Such assistance depends entirely on your description of the difficulty and any tests performed. Be as complete as possible.

The serial number of the amplifier which is on the cover of this manual should be mentioned in all correspondence, and whenever a part or the unit is returned to the factory.

When shipping the amplifier to Dynaco Inc. for service, include a note listing the symptoms, the name and address of the sender, and the serial number of the unit. Pack the unit securely to withstand the abuses of handling in transit. The complete original packing, if properly used, and in good condition, will be sufficient for Express or U.P.S. shipment. **PARCEL POST IS NOT A SAFE METHOD OF SHIPMENT, AND SHOULD NOT BE USED.** If no alternative is available, the unit must be double-packed with substantial packing between the cartons, and *it must be insured.*

Shipments should be made by insured prepaid Express, Motor Freight, or United Parcel Service. Serviced units will be returned by Express or United Parcel Service, collect for all transportation and service charges, unless these charges have been prepaid.

Dynaco reserves the right to limit the service facility or the established service fees to one year from the date of purchase. Dynaco assumes no liability or responsibility for damages or injuries sustained in assembly or operation of this equipment.

## PARTS LIST

Parts of similar type which do not change performance will sometimes be included as a matter of expediency. This will account for slight variations in value and appearance.

	PART #	Envelope #1	PART #	Envelope #3	PART #
1 Transformer, power, FA-704	464001				
2 Circuit board assembly, amplifier, PC-14	552001	2 Binding post with hardware, black	315001	4 Foot, rubber	859001
1 Circuit board assembly, power supply, PC-15	551001	2 Binding post with hardware, red	315002	34 Lockwasher, #6	617305
2 Heat sink, amplifier, with 2 mounted transistors	924001	1 Fuse holder with hardware	341001	4 Lockwasher, #8	617405
1 Heat sink, power supply, with 1 mounted transistor	934001	2 Socket, input	355001	1 Lug, ground	639308
1 Bracket, 1 3/8" diameter	717001	1 Switch, power	334301	4 Nut, hexagonal, #4-40	614245
1 Bracket, 1 1/2" diameter	717002	1 Terminal, 2-lug, long	372001	36 Nut, hexagonal, #6-32	614355
2 Bracket, 2" diameter	717003	1 Terminal, 2-lug, short	372002	4 Nut, hexagonal, #8-32	614465
1 Bracket, 2 1/2" diameter	717004			6 Screw, machine, #4-40 x 1/4"	611245
1 Capacitor, 500 mfd @ 100 v.	284507	Envelope #2		29 Screw, machine, #6-32 x 1/2"	611385
1 Capacitor, 1000 mfd @ 100 v.	284108	2 Capacitor, 0.1 mfd	265123	4 Screw, machine, #8-32 x 3/8"	611465
2 Capacitor, 3300 mfd @ 50 v.	283338	1 Fuse, 3 amp. Slo-Blo	341030		
1 Capacitor, 3300 mfd @ 100 v.	284338	2 Resistor, 4.7 ohm (yellow-violet-gold-silver)	125040	1 Card, guarantee	
2 Coil, #16 heavy wire	311016	2 Resistor, 0.47 ohm (yellow-violet-silver-silver)	128004	1 Manual, instruction	
1 Line cord	322092	11 Screw, #6-32 x 1 1/2"	611305		711001
1 Wire, hook-up, black		11 Spacer, tubular, 1"	764125		711002
1 Wire, hook-up, green		1 Strain relief, plastic	895001		
1 Wire, hook-up, red					

Do not remove the insulating covering on the five large capacitors (C7 left and right, C9, C11 and C12).